

2004 Achievement Report

International Project for the Efficient Use of Energy
International Project for Establishment of Infrastructure
for the Efficient Use of Energy
(Promotion of Energy Efficiency and Conservation
for Buildings in ASEAN Countries)

Report on the Results

March, 2005

The Energy Conservation Center, Japan

Summary

The ASEAN countries have continued rapid economic development. This will lead to a rapid increase in energy consumption. The rapid increase will require energy to be used more efficiently and measures be taken against global warming.

This project is called PROMEEC (Energy Management) in the ASEAN countries. PROMEEC is an abbreviation of “Promotion of Energy Efficiency and Conservation.” It is a project authenticated by the meeting of the secretaries of the energy-related ministries in ten ASEAN countries, being backed up by the Ministry of Economy, Trade and Industry in Japan. The project has been undertaken since 2000 to transfer technologies and experiences of Japanese energy conservation in the fields of major industries and buildings. The valid energy conservation technologies and energy management approaches transferred to all of the ten countries by 2003 include:

- OJT (One the Job Training) based instructions of energy audit technologies
- proposed corrective measures stemming from audit results.

This transfer was accompanied by the provision of support on evaluating an award system for excellent buildings in energy conservation. We are pleased to hear that the award system has been implemented actively in ASEAN countries. Since this year, we will aim to take measures for further enhancing effects of energy conservation based on the past activity achievements, as well as to make the basic system for propagation more secure. In other words, we will focus on:

- undertaking a follow-up investigation in the factories and buildings in the major industrial sectors already audited in terms of energy conservation;
- auditing the degree of energy conservation on the OJT basis for new factories and buildings with a view to securing transfer of energy diagnosis technologies; and
- creating a technical directory as a valid means for implementation and dissemination, as well as establishing databases, benchmarks, and guidelines.

In addition, we have launched out into a “Project for Implementing an Energy Management Infrastructure” in order to effectively improve energy management in the target regions. The project intends to build as its major objective an ASEAN Energy Management System that can be shared among the ASEAN countries.

This report targets the following three projects that were undertaken this year.

- Project for promoting energy conservation in the major industrial sectors of the ASEAN countries
- Project for promoting energy conservation for buildings in the ASEAN countries
- Project for implementing the energy management infrastructure in the ASEAN countries

The above three projects began with designing and identifying actual plans and their preparatory requirements through an inception workshop common to those projects. The projects ended with sharing their results and achievements, and with defining a basic policy for encouraging energy conservation in the future through a post-workshop. To enable the ten ASEAN countries to

tackle those projects, the workshop appointed the ASEAN Center for Energy (ACE) as the partner for coordinating those countries. The ACE has been assigned tasks for arranging and adjusting site jobs, and identifying data and information required for the Japanese partner. We contracted with the ACE for coordination immediately before the inception workshop and immediately after the post-workshop to detail requested jobs and programs, and the future basic plan.

The following gives the specific activities taken through the projects.

1. Kickoff meeting for coordination: July 12 to 15, 2004 (Dispatched in the period of July 11 to 16, 2004)

(Place) Indonesian ACE center (located in Jakarta)

We negotiated with the ACE members about details of the program of this year to be discussed through the inception workshop, that is to arrange site jobs and identify preparatory requirements.

2. Inception workshop: August 25 and 26, 2004 (Dispatched in the period of August 24 to 27, 2004)

(Place) Denpasar in Indonesia

(Designation) "Inception Workshop of on Promotion of Energy Efficiency and Conservation (PROMEEC) (Major Industry, Building and Energy Management), SOME – METI Work Program 2004 – 2005"

The representatives of Laos and Brunei were absent. Nearly 20 persons including the representatives of the ASEAN countries, and members of the ACE and the Energy Conservation Center, Japan (ECCJ), however, attended the workshop for discussion. For details on the program, see Attachment-1.

Opening statements (by the representatives of the host and relevant countries)

Session 1: Descriptions and discussions of activity policies in phases 1 and 2 (including evaluations of phase 1) (ECCJ)

Session 2: Presentation of Japanese cooperation in energy management (ECCJ)

Session 3: Presentation by the representatives of the ASEAN countries on lessons of phase 1 and on expectations for phase 2

Session 4: Presentation of programs on the three projects by the representatives of the ASEAN countries

Session 5: Final confirmation through explanations and discussions of the program undertaken in 2004 and 2005

3. Implementation of the three projects

After the end of the inception workshop, the three projects launched out into their own activities.

4. Post-workshop: February 7 to 9, 2005 (Dispatched in the period of February 6 to 10,

2005)

The post-workshop followed the summary workshop for the three projects.

(Place) Singapore

(Designation) “Summary Workshop and Post Workshop on Promotion of Energy Efficiency and Conservation (PROMEEC) (Major Industry, Building and Energy management), SOME – METI Work Program 2004 – 2005”

The representatives of Brunei and Vietnam were absent. 21 persons including the representatives of the ASEAN countries, and members of the ACE and the Energy Conservation Center, Japan (ECCJ), however, attended the workshop for discussion and summarization. For details on the program, see Attachment-1.

Opening statements (by the representatives of the host and relevant countries)

Summary workshop: Summarization of the results and achievements of the three projects, and creation of a policy program in the next year

Session 1: Identification of results and achievements of activities for the major industrial sectors

Session 2: Reporting of energy conservation for buildings

Session 3: Understanding of appropriate energy management

Post-workshop

Session 1: Total understanding of the achievements of discussions on the summary workshop for each of the projects

Session 2: Design of a basic plan for the next and subsequent years

5. Second meeting for coordination: March 16 to 18, 2005 (Dispatched in the period of March 15 to 19, 2005)

(Place) ACE center located in Indonesia (Jakarta)

We checked accounting records, discussed and summarized down the concrete contents of the basic plan for the next year agreed to in the post-workshop.

For details on the report of above meetings for coordination and of the workshops we have attended, see Attachment-2.

Contents

Preface

Summary

Overview

I. Purposes of This Project, and Its Development	I-1
II. Indonesia	II-1
1. Activity Overview	II-1
2. Recent Trends of Energy Conservation and Building Management in Indonesia	II-2
2.1 Recent Trends of Energy Conservation in Indonesia	II-2
2.2 Trends of Building Management in Indonesia	II-2
3. Energy Audit of JW Marriott Jakarta	II-3
3.1 Outline of JW Marriott Jakarta	II-3
3.2 Analysis of Current Status	II-4
3.3 Points for Improvement and Expected Effects	II-10
4. Energy Audit of Intercontinental Midplaza Jakarta	II-13
4.1 Outline of Intercontinental Midplaza Jakarta	II-13
4.2 Analysis of Current Status	II-15
4.3 Points for Improvement and Expected Effects	II-20
5. About the Result of the Workshop	II-24
5.1 Outline	II-24
5.2 Discussion on the Survey Results (Obstacles in Performing and Disseminating Energy Conservation Measures and Countermeasures)	II-24
5.3 Policy on Creating the Technical Directory	II-25
5.4 Discussion for Establishing the Database, Benchmarks, and Guidelines in Indonesia	II-27
III. Cambodia	III-1
1. Activity Overview	III-1
2. Recent Trends of Energy Conservation and Building Management in Cambodia	III-2
2.1 Trends of Energy Conservation in Cambodia	III-2
2.2 Trends of building management in Cambodia	III-3
3. Follow-up Energy Audit of Sofitel Royal Angkor Hotel	III-4
3.1 Sofitel Royal Angkor Hotel Overview	III-4
3.2 Outlined Results of the Energy Audit in 2002	III-5
3.3 Follow-up of the Previous Proposals	III-6
3.4 Results of Energy Audit	III-8
3.5 The Barriers for the Promotion of Energy Conservation, and Measures Against Those Problems	III-13
4. Energy Audit of Angkor Palace Resort & Spa	III-14
4.1 Outline of Angkor Palace Resort & Spa	III-14

4.2	Analysis of Current Status	III-17
4.3	Points for Improvement and Expected Effects.....	III-23
5.	About the Result of the Workshop	III-25
5.1	Outline.....	III-25
5.2	Discussion on the Survey Results (Barriers in Implementing and Disseminating Energy Conservation Measures and Countermeasures)	III-25
5.3	Policy on Creating the Technical Directory	III-25
5.4	Discussion for Establishing the Database, Benchmarks, and Guidelines in Cambodia.....	III-27
IV.	Thailand	IV-1
1.	Activity Overview.....	IV-1
2.	Recent Trends of Energy Conservation and Building Management in Thailand.....	IV-2
2.1	Recent Trends of Energy Conservation in Thailand	IV-2
2.2	Recent Trends of Building Management in Thailand	IV-3
3.	Follow-up Energy Audit on EGCO TOWER.....	IV-5
3.1	EGCO TOWER Overview	IV-5
3.2	Outlined Results of the Previous Energy Audit	IV-8
3.3	Results of Implementing Previous Proposals.....	IV-10
3.4	Results of Energy Audit	IV-12
3.5	Problems with and Measures for the Promotion of Energy Conservation.....	IV-15
4.	About the Result of the Workshop	IV-17
4.1	Outline.....	IV-17
4.2	Discussion on the Survey Results (Obstacles in Performing and Disseminating Energy Conservation Measures and Countermeasures)	IV-17
4.3	Policy on Creating the Technical Directory	IV-17
4.4	Discussion for Establishing the Database, Benchmarks, and Guidelines in Thailand	IV-19
V.	The Philippines	V-1
1.	Activity Overview.....	V-1
2.	Recent Trends of Energy Conservation and Building Management in the Philippines .	V-2
2.1	Trends of Energy Conservation in the Philippines.....	V-2
2.2	Trends of Building Management in the Philippines.....	V-4
3.	Follow-up Audit on Tower One & Exchange Plaza.....	V-5
3.1	Tower One & Exchange Plaza Overview.....	V-5
3.2	Outlined Results of the Energy Audit in 2002	V-6
3.3	Follow-up Investigation on the Previous Proposal	V-7
3.4	Results of Energy Audit	V-8
3.5	Problems with and Measures for the Promotion of Energy Conservation.....	V-17
4.	Energy Audit of DPC Place.....	V-19
4.1	Outline of DPC Place.....	V-19
4.2	Analysis of Current Status	V-22
4.3	Points for Improvement and Expected Effects.....	V-27
5.	About the Result of the Workshop	V-31

5.1	Outline.....	V-31
5.2	Discussion on the Survey Results (Obstacles in Performing and Disseminating Energy Conservation Measures and Countermeasures)	V-31
5.3	Policy on Creating the Technical Directory	V-31
5.4	Discussion for Establishing the Database, Benchmarks, and Guidelines in the Philippines	V-33
VI.	Approach as ASEAN	VI-1
1.	Summary Workshop Overview	VI-1
2.	Results of Addressing Barriers and Measures for the Promotion of Energy Conservation on Buildings.....	VI-2
3.	Creation of the Technical Directory, and Discussions of Dissemination Policies	VI-3
4.	Discussions on the Establishment of Databases, Benchmarks and Guidelines.....	VI-5
VII.	Created Technical Directory	
VIII.	Reference	
1.	Results of the follow-up survey and energy audit	
2.	Data for the workshop Presentation of achievements by ASEAN countries (ASEAN) Basic concepts and contents of the technical directory (Japan) Planned System of establishing databases, benchmarks and guidelines (Japan)	
3.	Summarized workshop data Report of activities in countries (Japan) ASEAN's benchmarking activities (ASEAN) Basic draft plan for 2005 and 2006 (Japan)	

Overview

The ASEAN countries have continued rapid economic development. This will lead to a rapid increase in energy consumption. The rapid increase will require energy to be used more efficiently and measures to be taken against global warming.

This project has entered the fifth year since it was embarked. The ACE as a partner, and relevant organizations in the ASEAN countries have deployed more active, concrete activities. The ASEAN countries have sharpened their attitude toward a reduction in energy consumption, being triggered off by the increase in the energy price that reflects the recent oil price and by the enforcement of the Kyoto protocol on February 16, 2005.

This year has been positioned as the first year for arranging the achievements of the project activities in the past four years and for actively tackling the second phase toward implementing and spreading the past achievements through more intensive self-efforts. In other words, the second phase aims to implement and disseminate actual measures taken and achievements found in the ASEAN countries according to data and records on energy audit for buildings in those countries in the past four years. We have deployed the following concrete activities in Indonesia, Cambodia, Thailand and the Philippines.

- To understand problems with taking and spreading actions based on the past follow-up investigation and simple energy audit for new buildings with a view to fixing measures for improvement
- Creation of the technical directory
To introduce technologies applicable to the ASEAN countries and successful case studies to share information and ensure that those technologies are implemented and spread
- Establishment of databases, benchmarks and guidelines
To attempt to implement a system for providing guidelines to set numeric objectives for encouraging energy conservation and attain those objectives. The establishment intends to tie up with ASEAN benchmarking activities deployed in the whole ASEAN region, and to allow the National University of Singapore (NUS) to implement systems particular to the ASEAN countries.

In addition, this project will cover activities for offering support on evaluating the system to commend a best-practice building in terms of energy conservation in the ASEAN countries.

We have carried out investigations including energy audit, and held workshops in the above countries. Through those investigations, we provided site relevant staff members with concrete instructions as checking what extent they have mastered about energy audit technologies, transferred by Japanese experts. Thus, we have contributed to secure technology transfer and more enhanced dissemination.

In addition to the above discussion, the workshops held in the ASEAN countries were attended by relevant staff members in those countries responsible for managing buildings and best-practice buildings characterized by effective energy conservation. They reported the contents of their concrete activities, and examples of taking measures for improvement. Many

persons participated in those workshops, which fulfilled great roles for sharing and spreading information.

This year, site project activities started with the inception workshop (common to both projects for the major industrial sector and for implementing the energy management infrastructure) in late August 2004. Those activities ended with summary/post-workshops (common to both projects for the major industrial sector and for implementing the energy management infrastructure) in early February 2005.

The inception workshop set out and identified a program to enable the smooth start of the project, confirming the preparatory step for site jobs. It was followed by successful investigations and workshops in four countries by December 2004. The summary workshop and post-workshop were attended by the representatives (focal point) of the ASEAN countries. They reported the results and achievements of activities in the four countries to allow the other countries to share the records of ASEAN benchmarking activities. Those representatives discussed the creation of the technical directory, and addressed the establishment of national databases, benchmarks and guidelines to finally fix a project policy in the next and subsequent years.

The following gives the concrete contents of project activities for this year.

August 25 and 26, 2004 (Dispatched in the period of August 24 to 27, 2004)

“Inception Workshop of on Promotion of Energy Efficiency and Conservation (PROMEEC) (Major Industry, Building and Energy Management), SOME – METI Work Program 2004– 2005”
(Place) Denpasar in Indonesia (This workshop is common to both projects for the major industrial sector and for implementing the energy management infrastructure.)

The representatives of Laos and Brunei were absent. Nearly 20 persons including the representatives of the ASEAN countries, and members of the ACE and the Energy Conservation Center, Japan (ECCJ), however, attended the workshop for discussion.

Opening statements (by the representatives of the host and relevant countries)

Session 1: Descriptions and discussions of activity policies in phases 1 and 2 (including evaluations of phase 1) (ECCJ)

Session 2: Presentation of Japanese cooperation in energy management (ECCJ)

Session 3: Presentation by the representatives of the ASEAN countries on lessons of phase 1 and on expectations for phase 2

Session 4: Presentation of energy management programs by the representatives of the ASEAN countries

Session 5: Final confirmation through explanations and discussions of the program undertaken in 2004 and 2005

September 12 to 25, 2004: Primary site job in Indonesia and Cambodia

1. Follow-up investigation of the buildings surveyed in the past (only in Cambodia), and simple energy audit.

We investigated buildings at two sites in each of the countries, reporting the results of the investigation.

2. Workshop held in each country

This workshop was attended by 50 to 60 representatives of the countries. They made very active discussions, and positively exchanged information. The policies proposed by Japan to create the technical directory and generate databases, benchmarks and guidelines were accepted basically. We can, therefore, say that this workshop ended successfully.

- (1) Energy conservation policies and programs (presented by the ASEAN countries and Japan)
- (2) Presentation of case studies on energy conservation for buildings by representatives of the host countries and the other ASEAN countries
- (3) Examinations of the policy for creating the technical directory
- (4) Evaluations of policies for the host countries to establish databases, benchmarks and guidelines

October 31 to November 13, 2004: Secondary site jobs in Thailand and the Philippines

1. Follow-up investigation of the buildings surveyed in the past, and simple energy audit of new buildings

We carried out only the follow-up investigation at one site in Thailand, and conducted follow-up and simple audit investigations of buildings at two sites in the Philippines, reporting the results of the investigations.

2. Workshop in each country

This workshop was attended by 50 to 80 representatives of the countries. They made very active discussions, and positively exchanged information. The policies proposed by Japan to create the technical directory and establish databases, benchmarks and guidelines were accepted basically. We can, therefore, say that this workshop ended successfully.

- (1) Energy conservation policies and programs (presented by the ASEAN countries and Japan)
- (2) Presentation of case studies on energy conservation for buildings by representatives of the host countries and the other ASEAN countries
- (3) Examinations of the policy for creating the technical directory
- (4) Evaluations of policies for the host countries to establish databases, benchmarks and guidelines

February 7 to 9, 2005: Summary workshop and post-workshop (Dispatched in the period of February 6 to 10, 2005)

“Summary Workshop and Post Workshop on Promotion of Energy Efficiency and Conservation (PROMEEC) (Major Industries, Building and Energy management), SOME – METI Work Program 2004– 2005”

(These workshops, which are common to both projects for the major industrial sector and for implementing the energy management infrastructure, were held in Singapore.)

The representatives of Vietnam and Brunei were absent. These workshops were, however,

attended by 21 members including the representatives of the ASEAN countries, the ACE and the ECCJ for summarization and discussion. The representatives of four countries we had visited reported their prepared technical directories, and how their databases, benchmarks and guidelines had been established under their own policies. This reporting was followed by active discussions. The issue for the next and subsequent years is to make efforts to appropriately identify a way how to concretely proceed with actual tasks. We can, however, highly evaluate achievements of activities in this year by the ASEAN countries. The policy to put efforts on the project in the next and subsequent years was accepted basically by those countries.

Opening statements (by the representatives of the host and other countries)

Summary workshop

Session 1: Major industries

Session 2: Buildings

- Evaluations of the results and achievements for this year
- Presentation of programs for generating technical directories, and databases, benchmarks and guidelines in appropriate countries
- Introduction of ASEAN benchmarking and activities of Board of Judges related to award systems
- Policies to be coped in the next and subsequent years

Session 3: Energy management

Post-workshop

Session 1: Arrangement of discussions in the summary workshop for each project

Session 2: Design of a basic program for the next and subsequent years

In this year, we deployed high-level activities toward more active efforts to be made by the relevant countries with a view to backing up the secure implementation of an infrastructure for sustainable energy conservation activities in each of the ASEAN countries. All of the countries have cooperated positively in those activities, allowing us to attain successful results. On the other hand, we are and will be confronted with issues with deepening understanding for fully dealing with changes in those activities to implement an appropriate system in each country. Those issues, however, apparently reflect the penetration of the contents of this project, and its successful development.

We are very grateful to the ACE and its related governmental organizations, and appropriate building managers for full cooperation in this project.

I. Purposes of This Project, and Its Development

This project aims to encourage and disseminate energy conservation technologies applicable to buildings. For this aim, it attempts to back up the ASEAN's activities including operation of a system to select and present awards to buildings characterized by excellent energy conservation. This attempt will lead to contribution to spread measures for energy conservation in buildings in the ASEAN countries. Moreover, it will trigger off effective energy conservation and environmental preservation in those countries.

This project was set up mainly by the ACE in 2000 to reduce energy consumption in business buildings that had continued to increase in the ASEAN region. The ASEAN countries refer to this project as PROMEEC (Buildings). PROMEEC is an abbreviation of Promotion of Energy Efficiency and Conservation. This project was authenticated in the meeting of the energy-related secretaries of the ten ASEAN countries, being supported by the Japanese Ministry of Economy, Trade and Industry. This Ministry has cooperated in the operation of the system for commending ASEAN business buildings excellent in energy conservation technologies. This project focuses on:

1. Implementing closer cooperative relationships between the ASEAN countries and Japan in terms of energy conservation;
2. Encouraging more efficient energy consumption and conservation in buildings in the ASEAN countries;
3. Triggering off transfer of appropriate Japanese technologies and introduction of approaches excellent in energy conservation to the ASEAN countries;
4. Enhancing the ASEAN countries' capability through energy audit and OJT;
5. Establishing databases, benchmarks and guidelines for energy audit in the ASEAN countries
6. Backing up the management of the award system for excellent buildings in energy conservation through evaluation support.

Past discussions with the ACE and the ASEAN countries have resulted in the understanding that this cooperative project would be carried out in the following three phases. This year is considered as being important as we should determine the direction of activities of phase 2 in it. By March 2004 as phase 1, we could implement an infrastructure for deploying energy conservation activities under equal responsibilities imposed on each of the ten ASEAN countries. This implementation had resulted from achievements of activities in those countries.

Phase 1: To transfer technologies and experiences from Japan to the ASEAN countries

Phase 2: To take measures for improvement in the ASEAN countries through cooperation between Japan and those countries, and to disseminate those measures to other countries

Phase 3: To promote energy conservation through efforts by the ASEAN countries themselves

This year, we embarked on implementing an infrastructure for penetration and propagation based on that infrastructure. This implementation is predicated on the follow-up

investigation into the buildings subject to energy audits, created technical directories, and established databases, benchmarks and guidelines. Furthermore, in this year, we deployed relevant activities in Indonesia, Cambodia, Thailand, and the Philippines.

In each of the countries, we carried out cooperation by local authorities mentioned below:

- A follow-up investigation to understand the process of taking measures for improvement in the buildings subject to energy audits and to identify problems
- OJT-based simple energy audit for new buildings with a view to securely transferring energy audit technologies.

In addition, we held workshops to let invited instructors of ASEAN and other countries introduce successful improvement case studies and some current state-of-the-art technologies. This introduction will help those technologies to penetrate in the ASEAN countries. Moreover, we have designed concepts for encouraging the creation of the technical directory, and the establishment of appropriate databases, benchmarks and guidelines, and discussed the creation and establishment to identify the future direction. These activities intend to construct a core for building an infrastructure for energy conservation encouragement in the ASEAN countries and to implement a network for dissemination to other countries.

As the final step, we held a summary workshop under the presence of the representatives of the ASEAN countries to find a basic program that allows us to share the results and achievements of activities in those countries and enables active future activities.

The important objectives of this project that were not examined this year are:

- To attend a Board of Judges (BOJ) meeting held by the commission which is responsible for evaluating the award system for best-practice buildings in terms of energy conservation in the ASEAN countries
- To participate in concrete discussions for reviewing evaluation criteria to provide support
- To tie up with “ASEAN Benchmarking for Building” conducted by the ASEAN countries themselves to further enhance project effects

II. Indonesia

1. Activity Overview

In Indonesia, we carried out a simple energy audit at two hotels of JW Marriott Jakarta and Intercontinental Midplaza Jakarta. In addition, we held a workshop.

The following gives the ECCJ participants and task records.

Participants from the International Engineering Department of the Energy Conservation Center, Japan (ECCJ)

- Kazuhiko Yoshida (General Manager)
- Akira Kobayashi (Technical Expert)
- Yohichi Kita (Technical Expert)

Task records

Date		Description
September 12	Sunday	Left Japan and arrived at Jakarta.
September 13	Monday	Carried out an energy audit in JW Marriott Jakarta.
September 14	Tuesday	Carried out an energy audit in JW Marriott Jakarta.
		Carried out a simple energy audit in Intercontinental Midplaza Jakarta.
September 15	Wednesday	Carried out a simple energy audit in Intercontinental Midplaza Jakarta.
September 16	Thursday	Workshop
September 17	Friday	Reported the results of the simple energy audit in JW Marriott Jakarta.
		Reported audit results in Intercontinental Midplaza Jakarta.
September 18	Saturday	Holiday
September 19	Sunday	Left Jakarta for Cambodia.

The Australian Embassy was bombed out on December 9, three days before we arrived at Jakarta. The whole city was stressed to prepare against terrorism. We carried out our job under such circumstances. JW Marriott Jakarta was also destroyed in August 2003, and we found signs of this destruction.

Technical experts visited Indonesia in March 2002 to audit. The Landmark Center – Tower A. Flood due to heavy rain, however, made an energy audit impossible. The follow-up investigation has, therefore, no target buildings. Thus, we carried out a new energy audit in the two hotels.

The energy audit was conducted by the conventional approach consisting of:

- Pre-sending of a questionnaire;
- Collection of data and information necessary for the energy audit ; and
- OJT-based data inspection and measurement at the site to secure technological transfer.

The workshop provides a chance for the achievements of activities to be presented by managers of buildings that were subject to an energy audit , applied for an excellent bill commendation contest held by an ASEAN country, or marked the highest score in the

contest. This presentation aims to share and spread appropriate information, with instructors invited from Indonesia and other ASEAN countries.

2. Recent Trends of Energy Conservation and Building Management in Indonesia

2.1 Recent Trends of Energy Conservation in Indonesia

The following gives recent trends presented by the ACE.

2.2 Trends of Building Management in Indonesia

The following gives recent trends presented by the ACE.

3. Energy Audit of JW Marriott Jakarta

3.1 Outline of JW Marriott Jakarta

JW Marriott Jakarta is a high-class hotel with the Marriott brand. It is located at the center of Mega Kuningan Complex which was developed in the southern part of Jakarta City. The hotel was greatly damaged by the terrorist bombing in August 2003. Although JW Marriott Jakarta is still heavily guarded, which is not very convenient for the guests, it is recovering steadily in its sales. For our energy audit, Mr. H. Wahyudi Hadiatmo (Director of Engineering) accompanied us.

(1) Name: JW Marriott Jakarta



Figure II-3-1 Exterior of JW Marriott Jakarta

(2) Use: Hotel and apartment

(3) Size: Two floors below the ground, 32 floors above the ground. The hotel consists of the central section of all the floors except the top two floors. The apartment consists of the right and left wings of all the floors and the central section of the top two floors.

Total floor area (GFA): 29,447 m² (assumed value)

Number of guest rooms in the hotel: 333

- (4) Year of completion of construction: 2001 (three years old)
- (5) Outline of facilities (for the hotel section only)
- 1) Energy management system: The Building Automation System (BAS) is installed.
 - 2) Electrical systems

Transformers:	1,600 kVA × 3 units, 1,250 kVA × 1 unit
Emergency generators:	1,940 kVA × 4 units
Receiving power:	20 kV from PLN. Contract power: 2,595 kVA
 - 3) Air-conditioning systems

Water chillers:	Five units. Cooling power: 464 kW/unit (capacity of electric motors: 144.3 kW/unit)
Primary chilled water pumps:	22 kW × 5 units, Secondary chilled water pumps: 80 kW × 3 units (one unit is variable speed)
Air-conditioning system:	Air conditioners: 11 units, Fan-coil units: 148 units, VRV: 75 units
 - 4) Boiler facilities

Steam boilers (gas):	Two units, 8-bar 1000-kg/h steam, 500-kg/h hot water
----------------------	--

3.2 Analysis of Current Status

(1) Energy composition

The consumed electric energy was 13,691,823 kWh, which was 134,179,865 MJ. The consumed gas was 487,670 m³, which was 16,336,945 MJ. The ratio of the consumption of electricity and gas is 9:1 and the most consumed energy was electricity. This section describes the details of the consumed electric energy.

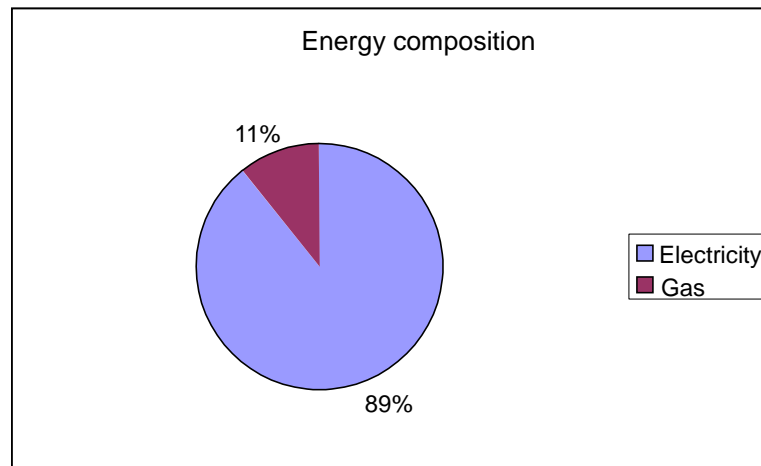

Figure II-3-2 Energy Composition

(2) Energy consumption

1) Monthly electric energy consumption

The following figure shows the changes of monthly electric energy consumption in the past three years. The consumption is decreasing a little every year. The consumption in August 2003 is 0 since the hotel was closed until September 7 to recover from the damage made by the terrorist bombing on August 5 of the same year.

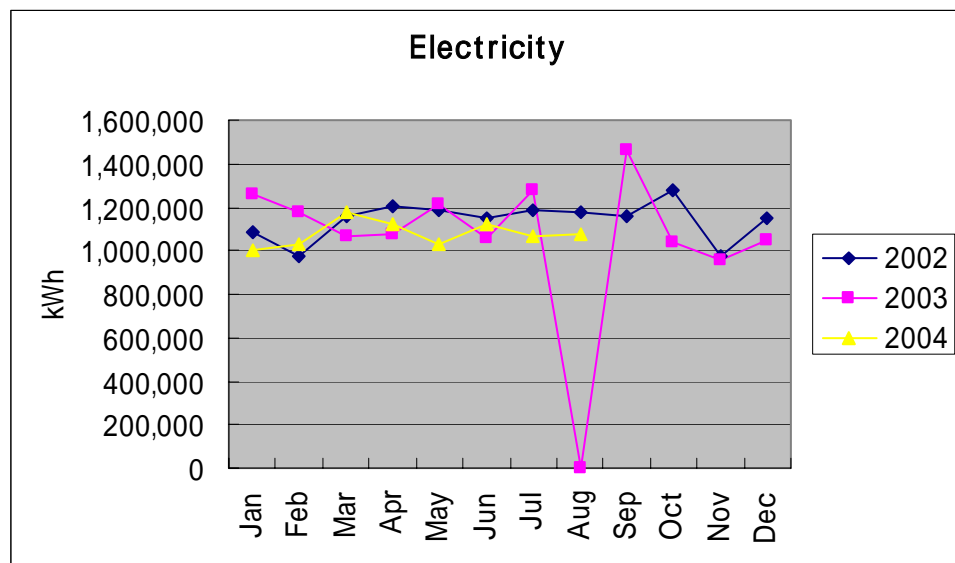

Figure II-3-3 Monthly Electric Energy Consumption

We need to mention the electric power pricing system in Indonesia. The electric power prices in the developing countries used to be unprofitable due to the complex government subsidies. Since the International Monetary Fund (IMF) strongly advised and guided the developing countries to raise their electric power prices to the international market level, each developing country is raising the electric power prices every year.

In Indonesia, as you can see in the following figures, the current electric power prices are higher than those of Landmark Center Tower we audited two and a half years ago (1 Rp is about 0.011 yen).

The electric power price in Indonesia consists of a fixed price (charged per demanded kW) and a variable price (charged per consumed kWh) like in Japan. However, the percentage of the fixed price is smaller compared to Japan. In addition, the power-factor discount for the fixed price is 5%, which is smaller than 15% at maximum in Japan.

There are different rates based on time of use, which is also the same as in Japan. However, the peak hours in Indonesia are from evening to night (18:00 to 22:00) whereas in Japan, the peak hours are the day time.

In Indonesia, 3% of the total charge is added to the charge for maintaining street lights and some types of industries receive 2.5% discount.

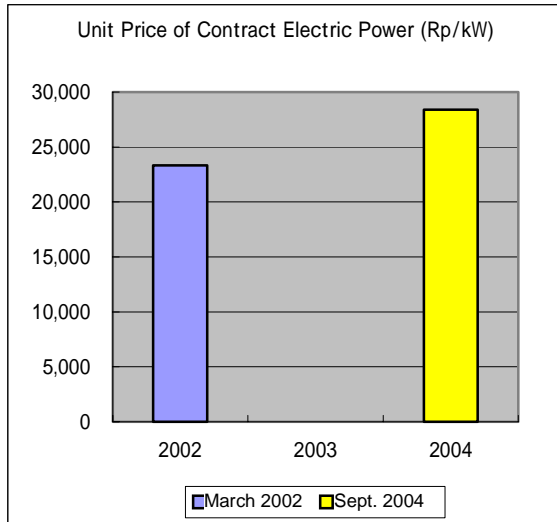

Figure II-3-4 Raised Unit Price of Contract Electric Power

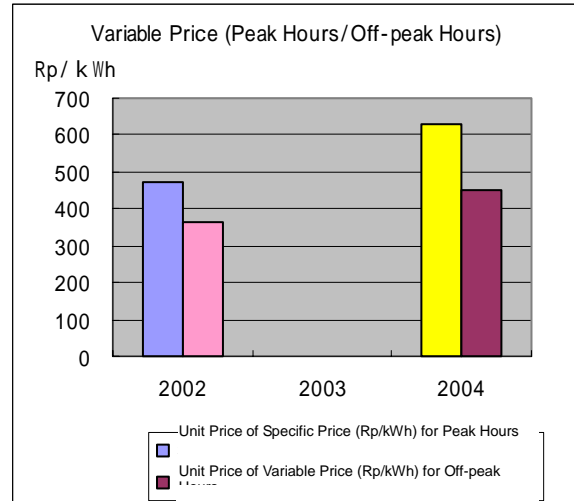

Figure II-3-5 Raised Unit Price of Electric Energy

2) Monthly gas consumption

The following figure shows the changes of monthly gas consumption in the past three years. The consumption is decreasing a little every year like electric energy.

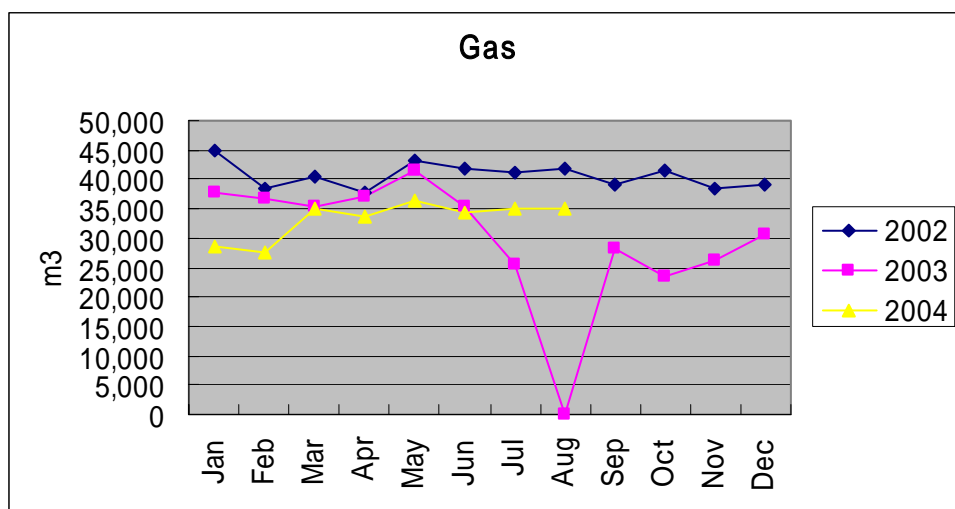

Figure II-3-4 Monthly Gas Consumption

3) Monthly water consumption

The following figure shows the changes of monthly water consumption in the past three years. The consumption is decreasing a little every year like electric energy.

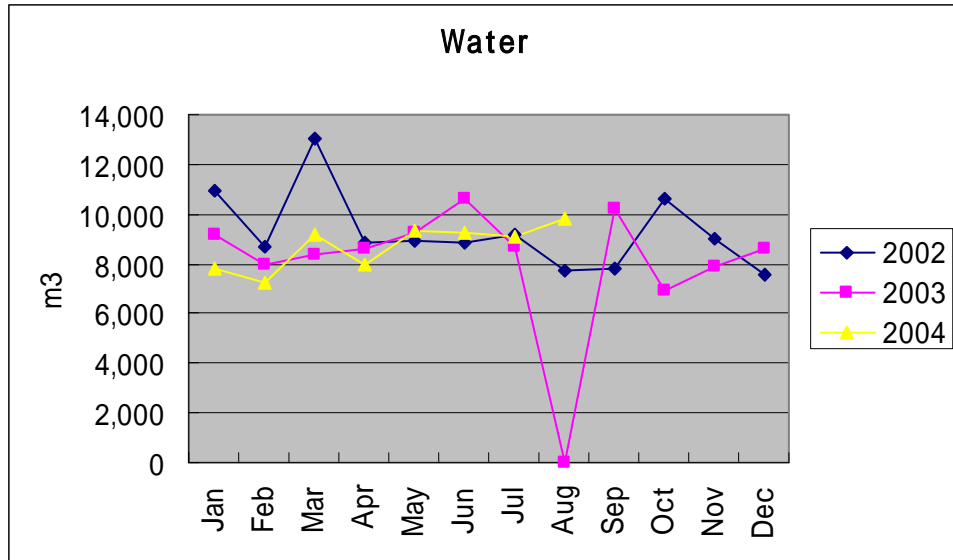

Figure II-3-5 Monthly Water Consumption

4) Changes of daily electric energy consumption

The following figure shows the daily changes of electric energy consumption in April and June in 2004. The consumption hardly changes daily or monthly.

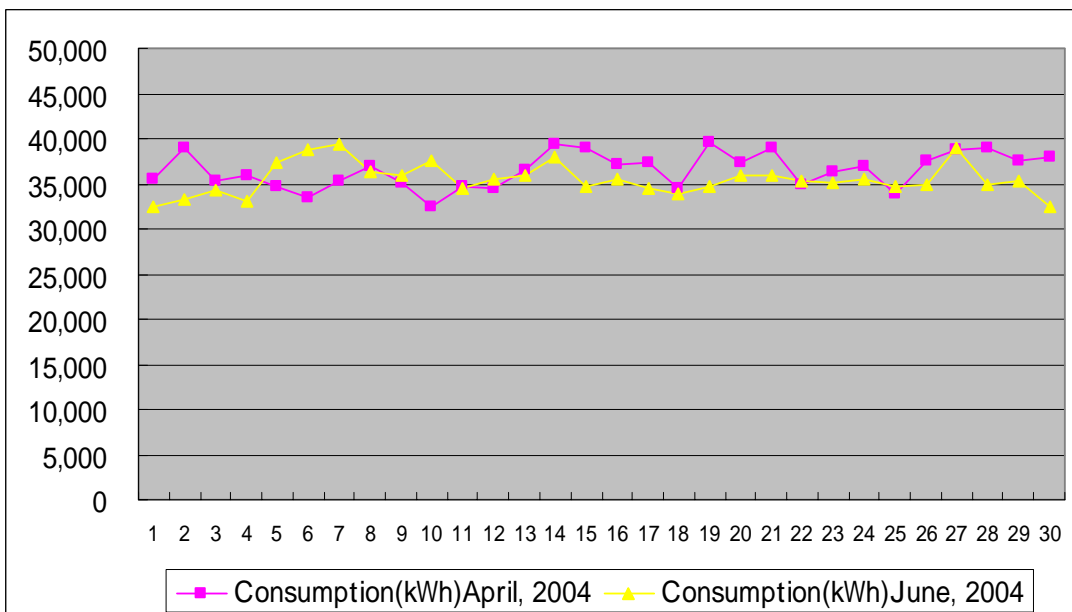

Figure II-3-6 Daily Electric Energy Consumption

(3) Evaluation of energy consumption

1) About GFA data

We estimated from the building drawings the Gross Floor Area (GFA) data to be used for calculating the consumption intensity.

The GFA of JW Marriott Jakarta is about 70% of that of the other hotel we audited in Jakarta (Intercontinental Midplaza) although the number of guest rooms is almost the same for both hotels. We are afraid that we may have underestimated the value.

2) Evaluation of electric energy consumption

We determined that the Energy Efficiency Index (EEI: annual electric energy consumption per index unit area) of the hotels in Indonesia was 300 kWh/m²/y on the average (based on a report in the workshop held on September 16 in Jakarta).

The electric energy consumption in Marriott is greater than the EEI (155%) as shown below.

Table II-3-1 Electric Energy Intensity of Marriott

GFA (total floor area in the hotel)	29,447 m ²	Electric Energy Intensity
Electric energy intensity	13,691,823 kWh	465 kWh/m ²
Annual electric energy consumption EEI EEI of Electricity For Indonesia(Research of ASEAN-USAID 1999)		300 kWh/m ²
Percentage in the average EEI		155%

3) Electric energy consumption per guest room

Like the resort hotel Angkor Palace Resort & Spa in Cambodia, Marriott seems to use, as the target indices of energy management, the electric energy consumption per guest room rather than the energy consumption per floor area in the building (EEI). This is probably because energy consumption per guest is a more understandable index for the operation of the hotel than the other energy related indices.

Figure II-3-7 shows the changes of electric energy consumption per guest room in April 2004 based on the received data. The bar graphs show the number of guest rooms used per day and the line graph (blue bold line) shows the electric energy consumption per guest room. Although the electric energy consumption does not change very much day to day, the electric energy consumption intensity greatly changes. This is because the number of the occupied guest rooms changes day to day.

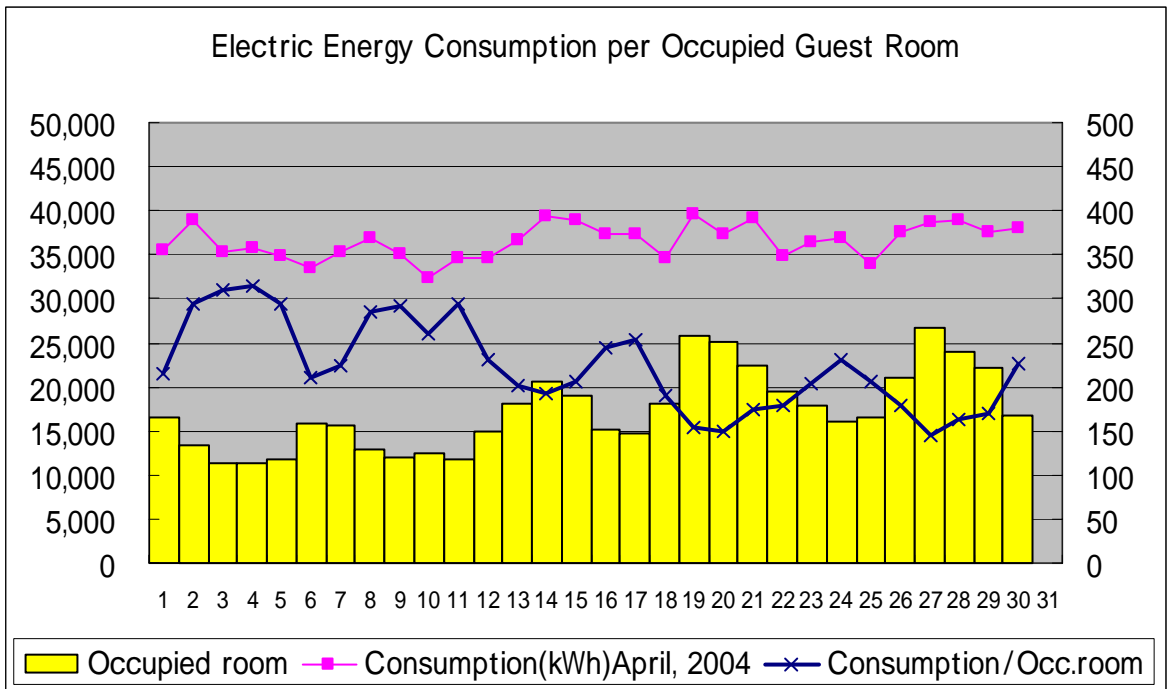

Figure II-3-7 Electric Energy Consumption per Guest Room

3) Considerations

As you can see in the table, the electric energy intensity of JW Marriott is higher than the Indonesian average by 50%. We may have estimated the GFA value smaller but still the intensity is higher than the average.

The facilities of this hotel were designed in consideration of energy conservation. For example, you need to consider the power for heat transfer in air-conditioning systems. In JW Marriott Jakarta, the lower floors are air-conditioned using AHUs and FCUs by sending chilled water from the chillers since they do not require much water transfer head. The middle and higher floors use air cooled packaged air conditioners to avoid using the chilled water of the chillers since they require much water transfer head. In addition, the inverter control VRV systems are used for efficient adjustment of the output of air conditioning power, which is based on the load.

However, the hotel's top priority is customer satisfaction. Therefore, guest rooms continued to be air-conditioned even after guests were out of their room, which is against energy conservation.

There was no ventilation control based on the room environment conditions, causing a consistent heavy load on processing the outside air. Consequently, the valuable facilities such as the VRV systems cannot effectively operate in the energy conservation zone.

The energy conservation of lightings was advanced. For example, most of

the incandescent lamps were replaced with florescent lamps.

3.3 Points for Improvement and Expected Effects

This section describes, based on the energy audit of the building and the analysis of the energy data this time, the items to be improved and the expected effects by these improvements.

(1) Optimization of the temperature settings of VRV units

The load decreases by raising the room temperature and the outside air intake temperature of the VRV units by 2°C. This makes inverter control more effective and reduces the electric energy consumption of all the VRV units by 25% (3.6% of the total).

Table II-3-2 Energy Conservation Effects Due to the Optimization of the Temperature Settings of VRV Units

VRV Outdoor Unit							
kW	Unit	hour	day	Load ratio	kWh	Reduction	kWh
7.5	75	24	365	0.4	1,971,000	0.25	492,750
kWh	Rp/kWh	Rp/y					
492,750	482.1	237,554,775	Hotel Total		13,691,823	kWh/y	3.6%

(2) Optimization of the chilled feed water temperature of chillers

The load decreases by increasing the chilled water temperature of the chillers by 2°C. This decreases the electric energy consumption of the chillers by 20% (1.9% of the total).

Table II-3-3 Energy Conservation Effects Due to the Optimization of the Temperature Settings of Chillers

Chiller							
kW	Unit	hour	day	Load ratio	kWh	Reduction	kWh
150	4	24	365	0.25	1,314,000	0.2	262,800
kWh	Rp/kWh	Rp/y					
262,800	482.1	126,695,880	Hotel Total		13,691,823	kWh/y	1.9%

(2) Optimization of the control of secondary chilled water pumps

The second important item for energy conservation we found out in the

operation log is the frequency of the secondary chilled water pump inverters. The difference in chilled water temperatures is 2 to 3°C and it seems to be a minor load. However, from another point of view, the flow rate of chilled water was excessive. The pumps were equipped with inverters. The inverters should lower the frequency to adjust the flow rate to an adequate value and decrease the input power. However, they were not done. The setting value should be studied and checked to operate the pumps with adequate energy consumption. The following table shows the effects on the energy saving by operating the pumps at 45 Hz rather than 50 Hz.

Table II-3-4 Energy Conservation Effects Due to the Control of Secondary Chilled Water Pumps

IF 50Hz →45Hz (0.9*0.9*0.9=0.73)

kW	Unit	hour	day	Load ratio	kWh	Reduction	kWh
37	1	24	365	0.8	259,296	0.27	70,010
kWh	Rp/kWh	Rp/y					
70,010	482.1	33,751,782	Hotel Total		13,691,823	kWh/y	0.5%

(3) Improvement of heat insulation of boilers and steam valves

We found some un-insulated parts in boilers and steam valves when we carried out the energy audit of the building. The gas consumption can be reduced by 3.7% by insulating the boilers and steam valves correctly.

Table II-3-5 Energy Conservation Effects Due to the Improved Heat Insulation of Boilers and Steam Valves

Assumption :Non Insulation Boiler Part & Valves = 15 Non Insulation Valves

Units	MJ/h/Unit	h	d	MJ	Boiler Efficiency	MJ
15	3.9	24	365	512,460	0.8	640,575
Gas MJ/m3	m3	Rp/m3		Rp/y		
33.5	19,122	1,513		28,931,044		
		Hotel Gas		513,234	m3/y	3.7%

(4) Reduced operation of fans in the parking lot

The fans in the parking lot used about 150 kW in total. If the operation of these fans can be reduced by two hours, 0.7% of the total electric energy consumption can be reduced.

Table II-3-6 Energy Conservation Effects Due to the Reduced Operation of Fans in the Parking Lot

If Car park Fan is shortened 2hours

kW	hour	day	Load ratio	kWh
154.4	2	365	0.8	90,170
kWh	Rp/kWh	Rp/y		
90,170	482.1	43,470,764		
Hotel Total	13,691,823 kWh/y			0.7%

(5) Summary of points for improvement

The following table lists the four items for improvement and their expected effects. The four improvement items can reduce 915,730 kWh, which is 6.7% of the electric energy used by the hotel. The amount of cost to be reduced is 470 million Rp.

Table II-3-7 Summary of Points for Improvement

No	Items	kWh/y	%	m3	%	Rp/y
1	In-door Setting of Temperature & Supply Air Temperature [VRV]	492,750	3.6%			237,554,775
	In-door Setting of Temperature & Supply Air Temperature [Chiller]	262,800	1.9%			126,695,880
2	Optimization of Secondary Chilled Water Pump	70,010	0.5%			33,751,782
3	Boiler & Steam Valve's Insulation			19,122	3.7%	28,931,044
4	Shortening of Carpark Fan	90,170	0.7%			43,470,764
	Total	915,730	6.7%		3.7%	470,404,246

4. Energy Audit of Intercontinental Midplaza Jakarta

4.1 Outline of Intercontinental Midplaza Jakarta

(1) Name: Intercontinental Midplaza Jakarta



(2) Use: Hotel and apartment

(3) Size: Four floors below the ground, 37 floors above the ground. Floor area: 131,653 m² (entire building)

Number of guest rooms in the hotel: 332,

Number of rooms in the apartment: 259

The areas of the floors below the ground, the hotel, and the apartment are shown in the table. The floors below the ground accommodate the parking lot, the machine room and the electricity room, and they are shared by the hotel and the apartment. The areas of these common floors below the ground are divided between the hotel and the apartment based on the ratio of the areas of the hotel and the apartment above the ground. In the subsequent calculations such as intensity, the area of the hotel is assumed to be 75,017 m².

	Area	Ratio of hotel and apartment	Area when the floors below the ground are divided based on the ratio
	[m2]		[m2]
Floors below the ground	53,486		
Hotel	44,540	0.57	75,017
Apartment	33,627	0.43	56,636
Total	131,653		131,653
Hotel and apartment	78,167		

(4) Year of completion of construction: 1998 (six years old)

(5) Energy management system: The Building Automation System (BAS) is installed.

(6) Outline of electrical systems:

Receiving voltage: 20 kV,

Transformers: 3000 kVA × 3 units,

Generators: 1940 kVA × 4 units (for emergencies such as power failures)

(7) Outline of air-conditioning systems

- a. Hotel: Water cooled chillers: 3 units with capacity of 2,020 kW (capacity of electric motors: 350 kW),
Primary chilled water pumps: 15 kW × 3 units, Secondary chilled water pumps: 90 kW × 2 units
Air-conditioning systems: air conditioners, fan-coil systems
Total heat exchangers: Three units
- b. Apartment: Water cooled packaged air conditioners, Enclosed type cooling towers: cooling capacity of 3,042 kW × 3 units,
Air handling units: 3 units, Air cooled chiller with cooling capacity of 375.7 kW

(8) Sanitary facilities

- a. Water supply system: Lift pumps: 55 kW × 2 units
- b. Hot water supply system: Steam boilers: 10 kg/cm², 1,000 kg/h × 2 units
- c. Heat machine (heat-pump water heater that collects the heat of laundry) × 3 units

4.2 Analysis of Current Status

(1) Monthly energy consumption

1) Monthly electric energy consumption

The following figure shows the monthly electric energy consumption in 2003. There is little variation in the hotel all year around. October and December show a little higher energy consumption for both the hotel and the apartment. November shows less energy consumption.

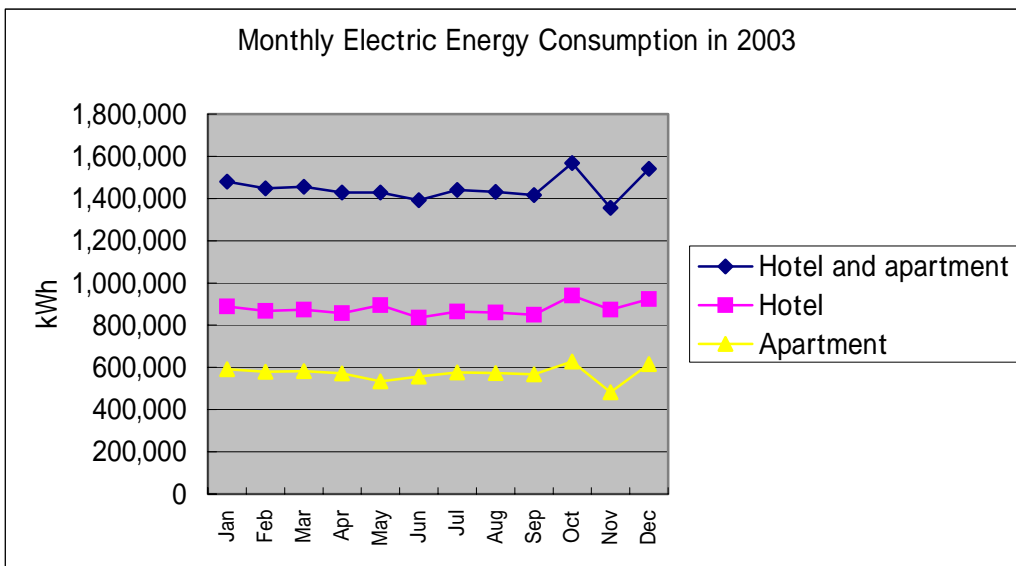

2) Monthly gas consumption

Gas was mainly used in the kitchens and for boilers for heating water. About 80% of the gas was used for boilers. The following figure shows the monthly consumption. The monthly changes are probably related to the changes in the amount of hot water supply, which may be related to the number of guests in the hotel.

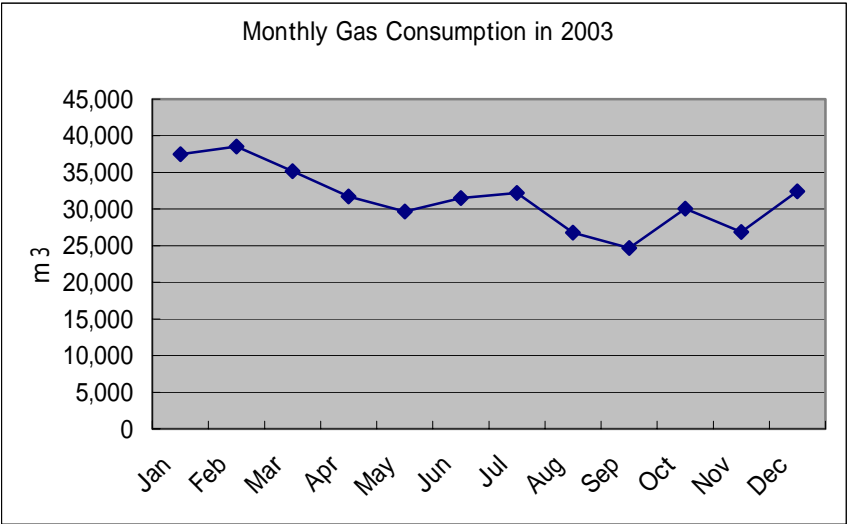

3) Monthly water consumption

The following figure shows the monthly water consumption in 2003. As this figure shows, October is higher than any other months. Since the electric energy consumption is also high in October, there may have been a big event in October.

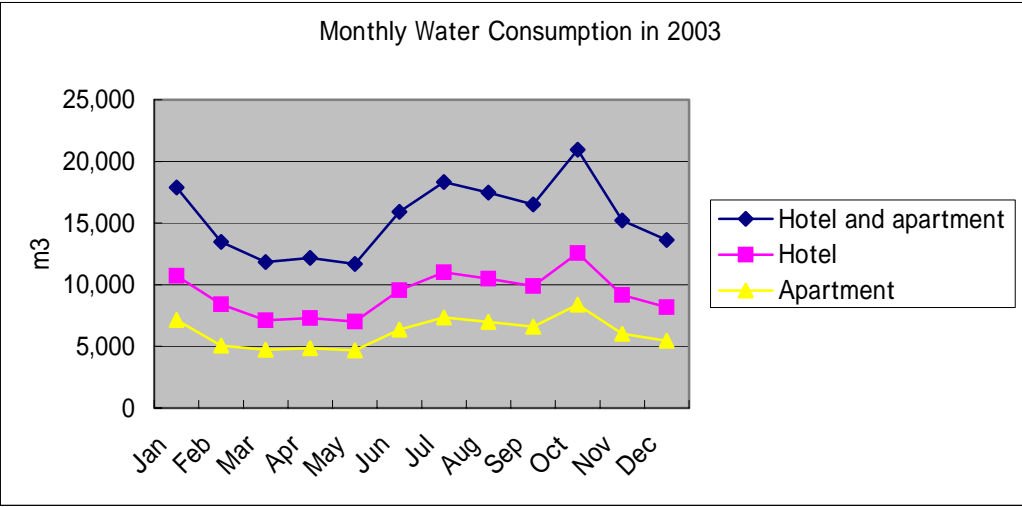

(2) 24-hour electric power demand in three days

The following figure shows the electric power demand of three sample days, Friday, Saturday, and Sunday. We chose these three days because they are the nearest to the day we conducted the audit in September. The pattern of electric power demand is the same for all three days except that Sunday is a little less. The peak hours are 19:00 to 21:00 and the lowest hours are 1:00 to 3:00 in the morning.

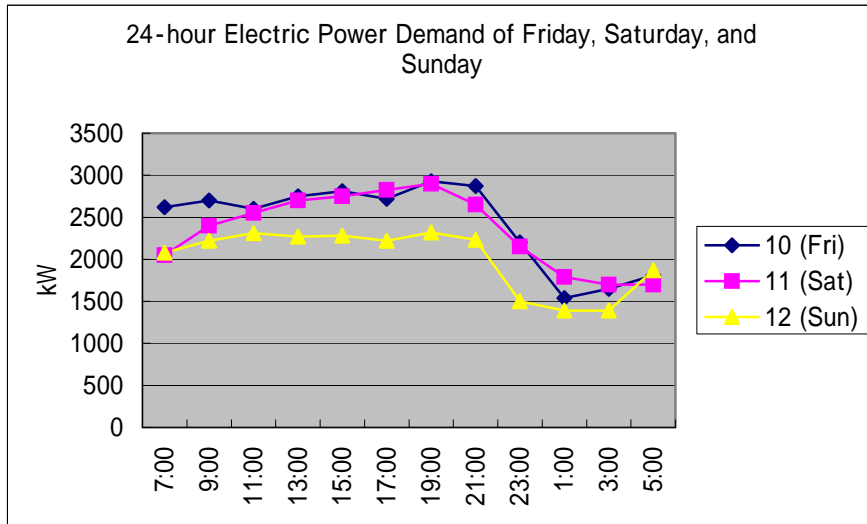

(3) Evaluation of energy consumption

1) Total evaluation for electric energy and gas

As mentioned in the outline, Intercontinental Midplaza Jakarta consists of the hotel section and the apartment section. Although the target of the audit was the hotel section only, the apartment section is used like a hotel since it is a high-class apartment. Here, we discuss two cases. One case is evaluating the entire building in regard to energy consumption. The other case is evaluating the hotel section only.

Since the energy for water heating in the hotel is considerably high, we convert the annual electric energy and gas consumption into the heat quantity unit, MJ, and divide this heat consumption by the floor area in order to determine the energy consumption per unit area. Since the comparison index, determined by combining electricity and heat, is not used in Indonesia, we compare the values with the average consumption values of the hotels in Japan.

The following two tables show the results of the calculations. When the floor area of the entire building is considered, the energy consumption of Intercontinental Midplaza Jakarta is 43% of the average of Japan. When the floor area of only the hotel section is considered, the energy consumption of the hotel is 48% of the average of Japan.

Table: Energy Consumption of the Entire Building and the Average Consumption of Hotels in Japan

Floor area of the entire building			131653 m ²
Annual electric energy consumption	17,385,000 kWh	9.8 MJ/kWh	170,373,000 MJ
Annual gas consumption	377,159 m ³	33.5 MJ/m ³	12,632,714 MJ
Total			183,005,714 MJ
Intensity per floor area			1,390 MJ/m ²
Average consumption of hotels in Japan			3238 MJ/m ²
Percentage of Midplaza's energy consumption in the Japanese average consumption			43%

Table: Energy Consumption of the Hotel Section and the Average Consumption of Hotels in Japan

Floor area of the hotel section			75017 m ²
Annual electric energy consumption	10,527,400 kWh	9.8 MJ/kWh	103,168,520 MJ
Annual gas consumption	377,159 m ³	33.5 MJ/m ³	12,634,827 MJ
Total			115,803,347 MJ
Intensity per floor area			1,544 MJ/m ²
Average consumption of hotels in Japan			3238 MJ/m ²
Percentage of Midplaza's energy consumption in the Japanese average consumption			48%

2) Evaluation of electric energy consumption

In the workshop held in Jakarta on September 16, the Energy Efficiency Index (EEI: annual electric energy consumption per unit area) of the Indonesian hotels was reported to be 300 kWh/m²/y. We take this value as the base value and compare it with the value of Intercontinental Midplaza Jakarta. As the following table shows, the entire building reaches 44% of the base value and the hotel section reaches 47% of the base value.

Floor area of the entire building	131,653 m ²	Electric energy intensity
Annual electric energy consumption	17,385,000 kWh	132.1 kWh/m ²
Percentage in the following EEI		44%
Floor area of the hotel	75,017 m ²	
Electric energy consumption of the hotel	10,527,400 kWh	140.3 kWh/m ²
Percentage in the following EEI		47%
EEI of Electricity For Indonesia (Research of ASEAN-USAID 1999)		300 kWh/m ²

3) Considerations

The combined energy consumption of electricity and gas is 43% of the EEI for the entire building. The energy consumption of electricity alone is 44% for the entire building. The combined energy consumption of electricity and gas is 48% of the EEI for the hotel section. The energy consumption of electricity alone is 47% for the hotel section.

Since there is not much difference in energy consumption between the entire building and the hotel section alone, energy is probably consumed in a similar manner in the apartment section as well.

When the energy consumption of Midplaza is compared with the Japanese average and the Indonesian average, it is around 40%, which indicates good energy conservation.

The possible reasons for this low-energy operation are as follows:

The building is well designed for energy conservation.

1. Card system for guest rooms
2. Total heat exchanger system for air conditioning
3. Heating water using the heat collected from the laundry room using heat pump

Excellent operation management

1. The operation time of equipment is adequately managed.
2. The temperature management of air conditioning is adequate (the return temperature on the first floor is 26°C).
3. Promotion of improvement activities (installing inverters in secondary chilled water pumps, replacing lamps)

Excellent communication between the management and the energy administrator and they work together to reduce energy consumption

4.3 Points for Improvement and Expected Effects

As mentioned above, the energy consumption is well managed. This section describes the points for improvement and the expected effects based on the tour of the building and the analysis of the energy data.

(1) Optimization of chilled water temperature settings

The cold heat source of the hotel was three chillers. The capacity of the electric motor of one chiller was 350 kW, which consumed the largest energy in the hotel. The operation log of this chiller on September 12, 2004 is shown in the following table (partly).

In this operation log, we noted two points for energy conservation. One is the chilled water temperature (Leaving Water Temp) and the other is the frequency of the secondary chilled water pumps (SCHWP Frequency).

The chilled water temperature was 6°C which was exactly the same as the setting (Chilled Water Set PT). This is not a problem itself. However, the setting of 6°C can be improved. The average return temperature of chilled water (Entering Water Temp) was 8.2°C and the temperature difference was 2.2°C which is rather small (generally, the difference is 5°C). We think the cooling load was small.

The electric energy consumed by the chillers can be reduced by increasing the efficiency of the chillers when the load is small. To increase the efficiency of the chillers, they need to raise the temperature of chilled water.

Chiller Log Sheet

12-Sep-04

	7:00	10:00	13:00	15:00	18:00	21:00	23:00	2:00	5:00	Average
Chilled Water Set PT	6.0	6.0	6.0	6.0	6.0	6.0	6.0	6.0	6.0	6.0
Leaving Water Temp	6.1	6.0	6.0	6.0	5.9	6.0	5.9	5.9	6.1	6.0
Entering Water Temp	8.3	8.4	9.0	8.4	8.3	8.4	7.4	7.3	8.1	8.2
Inlet Guide Vane Position %	38.1	51.2	60.8	48.0	47.2	46.7	23.3	21.8	32.4	41.1
Compressor kW	206	232	259	229	226	231	147	140	188	206.4
SCHWP Frequency	50	50	50	50	50	50	50	50	50	50.0

The following table shows the percentage of reduction in the input energy when the chilled water temperature of the chillers is changed from 6°C to 7.0°C, 7.5°C or 8°C.

Chilled water temperature	New temperature	Input reduction percentage
6.0	7.0	6%
6.0	7.5	9%
6.0	8.0	11%

The following table shows the reduction in electric energy and cost assuming the

temperature of chilled water is 7.5°C when the load is small. The annual reduction in electric energy is 220,752 kWh and the reduction in cost is 133,030,674 Rp. The reduced electric energy is 2.1% of the total electric energy consumed by the hotel.

kW	Number of chillers	Hours	Days	Load factor	kWh	Reduction rate	kWh
350	2	24	365	0.4	2,452,800	0.09	220,752
kWh	Rp/kWh	Rp/y					
275,940	482.1	133,030,674					

Electric energy consumed by the hotel	10,527,400 kWh	Percentage of reduction in the electric energy consumed by the hotel
Reduced electric energy	220,752 kWh	2.1%

(2) Optimization of the control of secondary chilled water pumps

The second item we noted in the operation log in regard to energy conservation is the frequency of the secondary chilled water pumps. The load might be small since the chilled water temperature difference was 2.2°C. However, from another perspective, the flow rate of chilled water was excessive. The pumps were equipped with inverters. The inverters should lower the frequency to adjust the flow rate to an adequate value and decrease the input power. However, they were not done. The settings can be modified to operate the pumps with adequate energy consumption. The following table shows the effects of operating the pumps at 45 Hz rather than 50 Hz. The reduction in the annual electric energy is 191,581 kWh and the reduction in cost is 92,361,427 Rp. The reduced electric energy is 1.8% of the total electric energy consumed by the hotel.

IF 50Hz →45Hz (0.9*0.9*0.9=0.73)

kW	Load factor	h	d	Reduction rate	KWH
90	0.9	24	365	0.27	191,581
kWh	Rp/kWh	Rp/y			
191,581	482.1	92,361,427			

Electric energy consumed by the hotel	10,527,400 kWh	Percentage of reduction in the electric energy consumed by the hotel
Reduced electric energy	191,581 kWh	1.8%

(3) Turning off the lights in the machine room and the electricity room

We found that lights were lit in the machine room and the electricity room when we toured the hotel. Although we are not sure whether the lights were lit for us, we calculate the effects when the lights in the backyard are turned off when there are no people.

There were 50 36-W fluorescent lights. We assume that those lights are lit 80% of the year. When the lights are turned off, the reduction in electric energy is 12,614 kWh and the reduction in cost is 6,061,402 Rp. The reduced electric energy is 0.1% of the electric energy consumed by the hotel.

kW	Number of lights	Hours	Days	kWh	Reduction rate	kWh
0.036	50	24	365	15,768	0.8	12,614
kWh	Rp/kWh	Rp/y				
12,614	482.1	6,081,402				

Electric energy consumed by the hotel	10,527,400 kWh	
Reduced electric energy	12,614 kWh	0.1%

(4) Improvement of lights in guest rooms

Some guest rooms used incandescent lights (100 W). We calculate the effects when the incandescent lights are replaced with 20-W highly-efficient fluorescent lamps (this improvement is planned to be performed). The reduced electric energy is 8,760 kWh and the reduction in cost is 4,223,196 Rp. The reduced electric energy is 0.1% of the electric energy consumed by the hotel.

100W	→	20W				
Reduced kW	Number of lights	Hours	Days	kWh	Load factor	kWh
0.08	300	2	365	17,520	0.5	8,760
kWh	Rp/kWh	Rp/y				
8,760	482.1	4,223,196				

Electric energy consumed by the hotel	10,527,400 kWh	
Reduced electric energy	8,760 kWh	0.1%

(5) Summary of points for improvement

The following table lists the four points for improvement and the expected effects. The four points can reduce 488,896 kWh, which is 4.1% of the electric energy used

by the hotel. The amount of cost to be reduced is 235 million Rp. The three points other than the fourth point (improvement of lights in guest rooms) are possible without renovating the hotel.

No	Item	kWh/y	%	Rp/y
1	Optimization of chilled water temperature settings	275,940	2.1%	133,030,674
2	Optimization of the control of secondary chilled water pumps	191,581	1.8%	92,361,427
3	Turning off the lights in the machine room and the electricity room	12,614	0.1%	6,081,402
4	Improvement of lights in guest rooms	8,760	0.1%	4,223,196
	Total	488,896	4.1%	235,696,699

5. About the Result of the Workshop

5.1 Outline

Eighty-one people participated in the workshop including Mr. Yogo Pratomo, Director General of Electricity and Energy Utilization of the Ministry of Energy and Mineral Resources, exceeding our expectation. Indonesia gave four presentations and three countries invited from the ASEAN gave three presentations. The workshop was a success with many questions and discussions including our report (the program is shown on the next page).

At the beginning of the workshop, Mr. Yogo Pratomo, Director General of the Ministry of Energy and Mineral Resources, gave an opening speech. Other participants include many government officials such as Ms. Ratna Ariati, Director of Renewable Energy and Energy Conservation, Ms. Mariam Ayuni, Chief of Energy Conservation, and many people from universities, laboratories and private businesses working in the field of buildings.

The presentations were very good and interesting including those from the invited guests. Through the presentations and discussions, we felt that the people involved were more eager to achieve energy conservation than we expected. We also noticed that they were trying to develop the technologies that match the ASEAN and that gave us some clues for future activities.

The people working in the field of buildings sensed that the government was trying to establish an energy conservation law to strengthen regulations and to establish a policy to cut back government subsidies in regard to the prices of energy. That is why those people were trying hard to achieve energy conservation.

Outside the workshop, we received requests from some people on holding more seminars and workshops in Jakarta and local cities of Indonesia.

5.2 Discussion on the Survey Results (Obstacles in Performing and Disseminating Energy Conservation Measures and Countermeasures)

We brought the results of the audit to each hotel we audited and discussed the measures for improvement. The details are not described here since they are mentioned in other sections in this report.

Intercontinental Midplaza Jakarta was especially advanced in energy conservation. The General Manager participated in the discussion and the response from the management was superb. We received total cooperation and witnessed decisive instructions to the people in charge in response to the results of our audit, which gave a great impression to us.

Since future follow-ups are required, we visited Ms. Ayuni at the Ministry of Energy and Mineral Resources in the evening to explain the results of the reports we made at the two hotels and asked for future follow-ups.

5.3 Policy on Creating the Technical Directory

We explained the basic concept and some elements of the Technical Directory at the workshop and obtained approval from the participants. The features are as follows:

- Include the technologies that are suitable for Southeast Asia and those that have been recommended by Japanese experts or those actually used in Japan.
- Include successful examples of the above.
- Prepare the basic format that can be easily expanded or changed in the future based on the above.

We asked the Indonesian side to prepare successful examples at least.

Workshop Program in Indonesia

- 08.00 - 08.30 Registration
- 08.30 - 08.35 Welcome Remarks
Dr. Yogo Pratomo
Director General for Electricity & Energy Utilization
- 08.35 - 08.40 Opening Statement
Dr. Yoshida Kazuhiko
General Manager, Energy Conservation Centre, Japan
- 08.40 - 08.45 Opening Statement
Dr. Weerawat Chantanakome
Executive Director, ASEAN Centre for Energy
- 08.45 - 09.00 Coffee Break & Photo session
- Session I : Policies and Programs on Energy Conservation
- 09.00 - 09.20 Energy Conservation Policy and Programs of Indonesia
Ms. Ratna Ariati
Director, Directorate General for Electricity and Energy Utilization
- 09.20 - 09.40 Japan's Energy Conservation Programs
Dr. Yoshida Kazuhiko
Energy Conservation Centre Japan
- 09.40 - 10.00 Question and Answer

- Session II : Energy Conservation Best Practices for Buildings in Indonesia
- 10.00 - 10.20 Natura Resort and Spa Bali
- 10.20 - 10.40 PT. Metropolitan Bayu Industri
- 10.40 - 11.00 Gran Melia Hotel Jakarta
- 11.00 - 11.20 Citra Land Building
- 11.20 - 11.40 Grand Preanger Hotel Bandung
- 11.40 - 12.30 Question and Answer
- 12.40 - 13.30 Lunch Break
- Session III : Energy Conservation Best Practices for Buildings in ASEAN Countries
- 13.30 - 14.15 Shinawatra University Building
Dr. Vorasun Buranakarn (Thailand)
- 14.15 - 15.00 Indirect Seawater Cooling & Thermal Storage System, Changi Naval Base
Mr. Ng Yew Soon & Er Tay Leng Chua (Singapore)
- 15.00 - 15.15 Coffee Break
- 15.15 - 16.00 Securities Commission Building
Mr. Chen Thiam Leong (Malaysia)
- 16.00 - 16.45 The 6750 Tower Building
Mr. Gerald Monasterio (Philippines)
- 16.45 - 17.15 *Discussion*
- 17.15 - 17.30 *Summary : Barriers and Measures*
- Session IV : Dissemination Procedure
- 17.30 - 17.45 Development of Technical Directory by ECCJ
- 17.45 - 18.00 Development of Local Database / Benchmark / Guideline by ECCJ
- 18.00 - 18.15 *Closing Statement*

5.4 Discussion for Establishing the Database, Benchmarks, and Guidelines in Indonesia

In the workshop, we explained the basic idea including how the system worked. The activities must be in cooperation with the ASEAN Benchmarking being performed by Singapore and other ASEAN countries. However, the database, benchmarks, and guidelines for Indonesia must be planned and established first.

In Indonesia, the benchmarks for the energy consumption intensity for buildings are already set based on the past energy audits and other survey data. However, the existing benchmarks (including those that are made based on our audits) need to be modified and improved.

III. Cambodia

1. Activity Overview

In Cambodia, we carried out a follow-up investigation into Sofitel Royal Angkor Hotel, and a simple energy audit at Ankor Palace Resort & Spa (hotel), as well as holding a workshop.

The following gives the participants and task records.

Participants from the International Engineering Department of the Energy Conservation Center, Japan (ECCJ)

- Kazuhiko Yoshida (General Manager)
- Akira Kobayashi (Technical Expert)
- Yohichi Kita (Technical Expert)

Task records

Date		Description
September 19	Sunday	Left Jakarta and arrived at Siem Reap.
September 20	Monday	Carried out the follow-up audit at Sofitel Royal Angkor Hotel.
September 21	Tuesday	Carried out the simple energy audit at Angkor Palace Resort & Spa.
September 22	Wednesday	Left Siem Reap, and arrived at Phnom Penh.
September 23	Thursday	Held the workshop.
September 24	Friday	Bargained with representatives of the Ministry of Industry, Mines and Energy (MIME).
September 25	Saturday	Left Phnom Penh for Japan.

We carried out the follow-up survey at Sofitel Royal Angkor Hotel where the energy audit was carried out in March 2002. Buildings have been constructed in Siem Reap that has Angkor Watt, a world heritage. Angkor Palace Resort & Spa is also a new hotel that was established recently. This area has no well arranged electric power supply network. The basic form of energy supply is self-generation by a diesel generator.

The follow-up investigation consists of:

- pre-sending of a questionnaire;
- identification of the achievements of taking the hotel's own measures and measures recommended particularly by the Japanese experts for more effective energy conservation, as well as understanding of latest energy consumption conditions
- site survey and evaluations.

We also pre-sent a questionnaire for an energy audit to collect data and information necessary for the energy audit. We adopted the conventional OJT-based approach for measuring and checking data at the site to secure technology transfer.

On September 23, we held the workshop at Phnom Penh attended by about 60 persons including four instructors invited from Cambodia and three other ASEAN countries. The

workshop ended successfully after active inquiries and discussions.

2. Recent Trends of Energy Conservation and Building Management in Cambodia

2.1 Trends of Energy Conservation in Cambodia

The following gives recent trends presented by the ACE.

In Cambodia, the MIME is responsible for designing and implementing energy conservation policies. But it has not recorded full achievements owing to insufficient funds and other reasons, though some achievements have been reported.

The most important energy source is firewood. Some people consider that petroleum, natural gas, coal, and other natural resource reserves are present in Cambodia. None have, however, identified the amount of those reserves. This country has a wealth of water, but is occupied by flat fields with fewer mountains. Possible water power is, therefore, estimated at about 10,000 MW.

95 percent of energy is obtained from petroleum, all of which is imported. It is applied mainly to transportation and power generation (public and self generation). Each of gasoline, kerosene, diesel oil and fuel oil has a nearly equal share.

In Cambodia, the major industrial energy is electric power. The current rate of electrification is no more than 20 percent. (In 2001, this rate was 15 percent.) Only Phnom Penh and local big cities, and their peripheral regions are electrified, and the other regions are supplied with no electric power. This makes it a most privileged issue to electrify the whole country. Following the MIME's program and policies, its underlying organization, the EDU (Electricite du Cambodge), assumes a major role for complete electrification. That program aims at supply of electric power of about 750 MW in 2016 through new development and import from peripheral countries. The current power supply is about 150 MW. Figure IV-1-1 illustrates the master plan of electric power generation and transmission prepared by the MIME.

Figure I-1-1 Master Plan of Electric Power Generation and Transmission in Cambodia

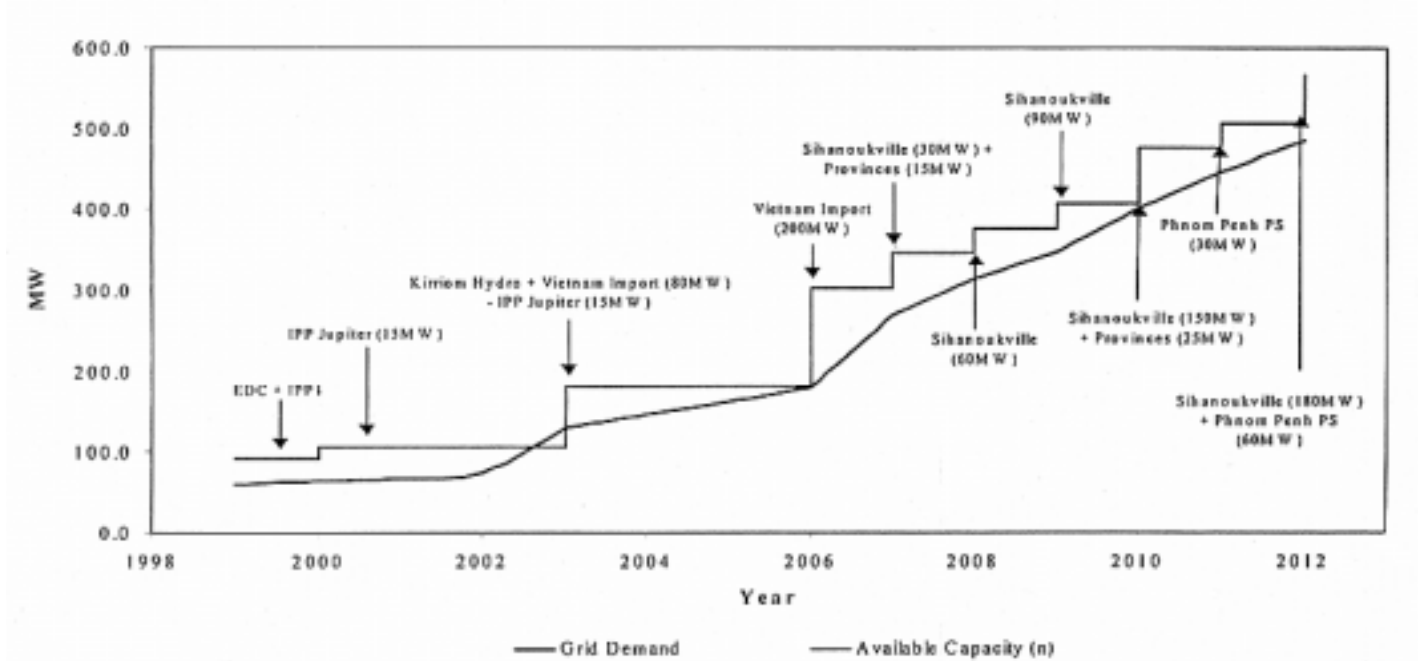

2.2 Trends of building management in Cambodia

The following gives recent trends of building management presented by the ACE.

3. Follow-up Energy Audit of Sofitel Royal Angkor Hotel

3.1 Sofitel Royal Angkor Hotel Overview

- (1) Name of the building: Sofitel Royal Angkor Hotel



- (2) Application: Hotel
- (3) Size: One story under and three stories above the ground
Total floor area: 70,000 m²
Number of guest rooms: 240
- (4) Constructed in: October 2000
- (5) Energy management system: Not adopted
This hotel is, however, equipped with the handmade monitoring instruments to check temperature and other conditions, and timers.
- (6) Electric power generation
All electric power is generated by the hotel itself using three air-cooled generators (1,500 kVA (1,200 kW), 1,000 kVA (800 kW), and 800 kVA (648 kW)).
Electric power (390 V, three phases, four wires) is supplied directly via no transformers.
Two elevators (each of which is rated at 7.5 kW), and one elevator rated at 5.5 kW
- (7) Air conditioning
a. Three air-cooled chillers

No. 1: Manufactured by York, Capacity: 200 RT × 210.5 kW
No. 2: Manufactured by York, Capacity: 210 RT × 228.2 kW
No. 3: Manufactured by Carrier, Capacity: 220 RT × 347.6 kW
Four cooled water pumps (each of which is rated at 18.5 kW)

- b. Air-conditioning systems
 - Guest rooms: 288 fan coil units
 - Lobbies, business rooms, meeting rooms, and other rooms: Air conditioners
 - Some rooms: Package system

(8) Sanitation

a. Water supply

Well: Water is pumped up from the underground of the site, which is 56 meters in depth below the ground level. The pump is rated at 4 kW.

Two water reservoirs: Installed underground. The capacity of each of the reservoirs is 400 m³.

One water tower: 100 m³

b. Water boilers

Two evaporation boilers (100 psi and 1,000 kg/h)

The boilers generate vapor of 60 to 80 psi to be sent to the laundry and the hot water reservoir for use as the hot water source.

c. Waste water treatment

A sewage treatment system is installed at the site to completely treat sewage and other water.

3.2 Outlined Results of the Diagnosis in 2002

- (1) The energy audit was carried out in March 7 and 8, 2002.
- (2) Diagnosed by: Toru Isome (technical expert) and Akira Kobayashi (technical expert) from the Energy Conservation Center, Japan
- (3) Outlined results of the diagnosis
 - 1) High-level energy management
 - Mr. Sumit Thungtong as the facility engineering manager manages energy excellently. He well manages the temperature of the cooled water outlet in the chiller, and runs the chiller under fully managed energy conservation. He correctly calculates energy costs of the guest rooms in use every day, and finely controls the timer to enable high-level management.

2) Three proposals for improvement

This hotel was constructed one year and five months ago, having new equipment. Because of the high-level energy management, it is difficult to find issues for improvement. We, however, proposed the following three points.

Introduction of a cogeneration system

Self-generation equipment is installed in this hotel since no electric power is supplied from the outside. As the hotel has demands for heat in terms of hot water and vapor supply, we proposed the introduction of a cogeneration system. Owing to new equipment, we recommended that this introduction will be studied in detail when the equipment has been aged.

Adoption of highly efficient lamps

Quite a few lamps are of highly efficient types but some are conventional lamps. We proposed that those conventional lamps should be replaced with highly efficient lamps.

Boiler's air ratio control

The hotel does not seem to control the air ratio which is an important factor for boiler control. We recommended that the air ratio be controlled to improve oil consumption by the boiler.

3.3 Follow-up of the Previous Proposals

The following describes how the above proposals have been implemented.

(1) Introduction of a cogeneration system

During the previous investigation, we proposed that a cogeneration system be introduced because they installed self-generation power equipment and had a demand for heat. The equipment has, however, already been improved so as to collect heat, run as "a simple cogeneration system" .

In order to collect heat from exhaust gas of the generator, copper pipes, in which water is flowing, are wound on the surface of the exhaust gas duct (See the photo below.) According to Mr. Sumit, 24 cubic meters of water are heated per day.

We had considered that it is difficult to install a real cogeneration system for the present air-cooled generator. We were, however, surprised at the installation of the excellent simple heat collection system with the copper water pipes wound on the duct.



Cambodia has not well constructed an electric power supply infrastructure. Large-size buildings including this hotel install such power generation equipment by themselves. Owing to the considerable demand for heat, a cogeneration system would contribute significantly to more efficient energy conservation. We, therefore, hope that real cogeneration systems will be installed at hotels and other facilities in Cambodia.

(2) Adoption of highly efficient lamps

The previous investigation found that nearly 500 conventional 40W fluorescent lamps were used. However, our proposal of the replacement of these lamps with more efficient lamps has already been implemented.

In addition, the hotel has a plan to install garden lamps with solar generation system and LED manufactured in Australia.

(3) Boiler's air ratio control

The boiler's air ratio is not controlled because of the absence of measuring gauges and the execution professionals. Supply water is, however, preheated by solar energy in order to reduce boiler operation load (see the photo below). In addition, this hotel has a plan to equip a hot water supply system that uses a heat pump to collect the laundry's heat for heating of water. The use of the heat pump for heat collection, which is a current advanced and sophisticated technology, is positive challenge for the energy conservation.



3.4 Results of Energy Audit

(1) Historical development of energy consumption

The following describes the three year records of energy consumption of this hotel which was constructed three years ago.

1) Monthly oil consumption during the period of the three years

The chart below indicates that more oil was consumed in November and December 2002 and significantly less oil was consumed in 2003 in comparison with the past two years.

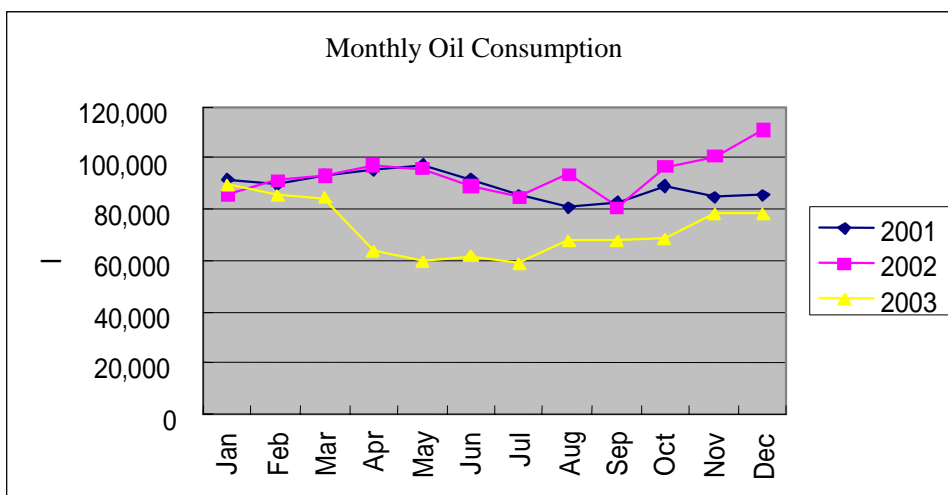

- 2) The rate of hotel operation and electric power consumption for the three years
 The chart below illustrates changes in the rate of hotel operation and electric power consumption for the three years. This rate of operation reduced in 2002 in comparison with the previous year, but marked the highest figure in 2003 in the past three years. On the other hand, electric power consumption has reduced steadily ever year. This reduction exceeds the target of an annual reduction of 3.5 percent set by Mr. Sumit.

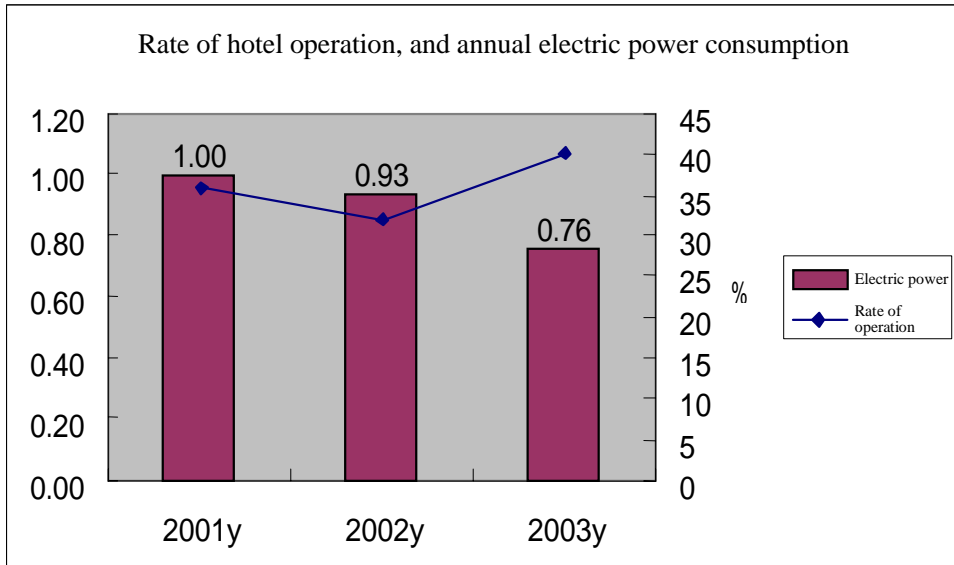

- 3) Daily changes in electric power consumption
 The chart below shows the changes of electric power loads for 24 hours on a typical day. Like the other general hotels, the electric power consumption reaches the peak at around 20 o'clock.

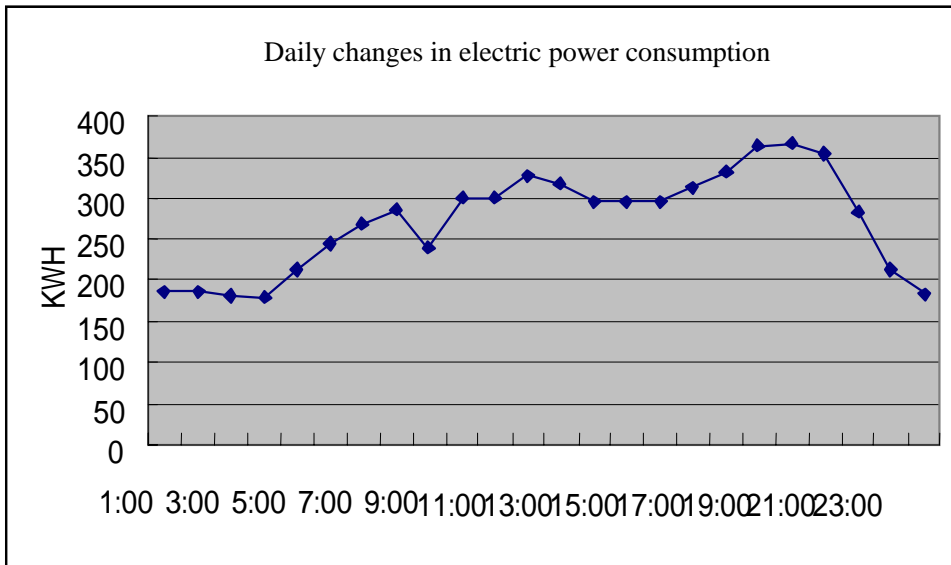

- (2) Evaluations of energy consumption

1) Comparison of the four hotels

As already explained, this hotel is characterized by excellent management by Mr. Suimt and the improvement of the energy consumption is positively implemented. This paragraph compares this hotel with other hotels in terms of energy consumption to understand the energy situation of this hotel.

Normally, for the comparison of energy consumption among buildings the index of the annual energy consumption per floor area is used. This hotel does not, however, provide the correct number of the total floor area . We, therefore, studied and proposed a new index for the evaluation. The new index is annual energy consumption divided by the number of guest rooms and the number of days in the year, which is the energy consumption per day • room.

The comparison are done between two high-rise city hotels in Jakarta, and the two resort-type hotels located at Siem Reap in this country.

The chart below provides the results of the comparison. This hotel consumes about 1/3 of the energy which Jakarta hotel A uses, and about 7/10 of the energy which Siem Reap hotel C consumes. This is affected by the results of energy conservation activities.

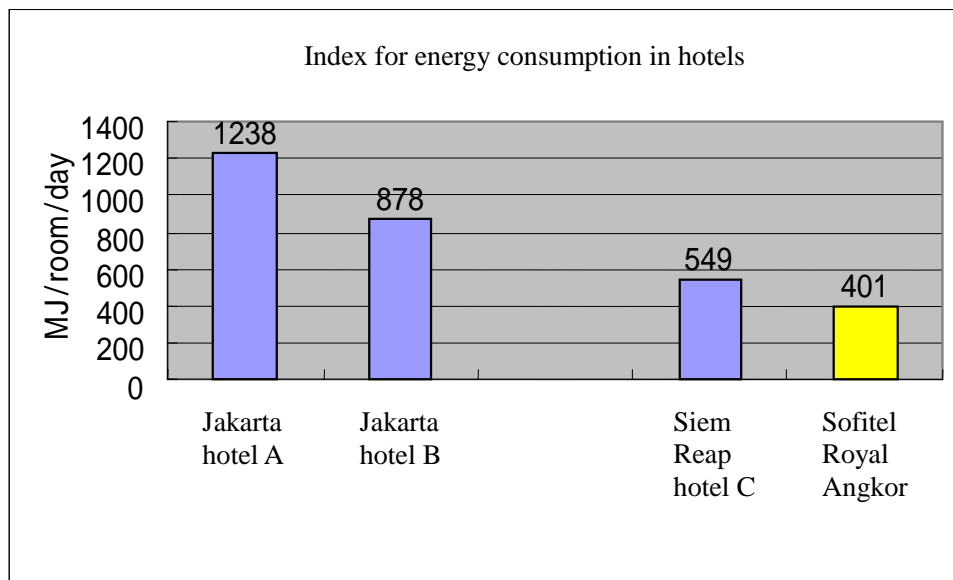

2) Electric power consumers

The pie chart below, which is created according to Mr. Sumit's presentation, shows the share of electric power consumers. Although the pie chart is significantly different from the previous offered one in terms of chiller plants and lighting outlets, it is considered as providing valid values. This is because an energy breakdown list is prepared currently to understand electric power consumption by equipment per hour.

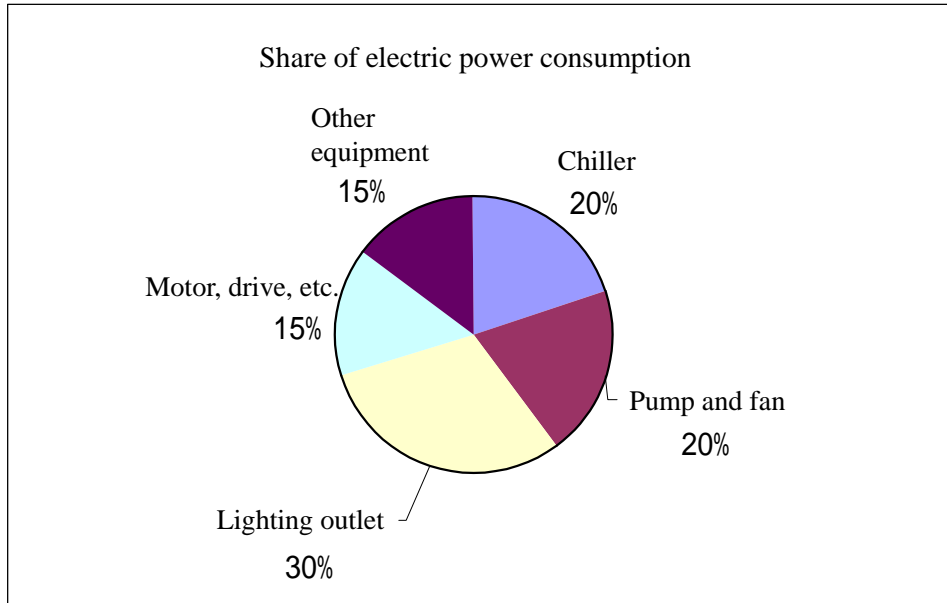

(3) Remarkably excellent energy management

The following sets out the concepts of remarkably excellent management found in our investigation.

1) Manually fabricated BTMS and timer control

This hotel is not provided with a so called BEMS (Building Energy Management System), a BAS (Building Automation System), and other centrally monitored controllers. As shown in the photo below, however, manually fabricated temperature meters and timers are installed on walls to perform efficient energy management. In particular, the timers checks set points twice a day to enable optimum management suitable for temperature and the number of guests. This management level is highly excellent, and may be superior to Japanese advanced equipment.



2) Effective methods for energy conservation

Helpful methods for energy conservation have been implemented actively, including thermal collection from generators, and solar energy utilization. The following covers other means with possible photos affixed.

Reuse of treated water

Treated waste water is reused for the cooling tower and for floor cleaning.



Natural laundry ventilation

The laundry is not ventilated by an existing machine, but naturally ventilated from new roof outlets under no power.



Ceiling ventilation and resulting reduction in air-conditioning loads

The top ceiling of the hotel guest building is ventilated to reduce thermal loads from the ceiling.

Water saver

The water taps in the guest rooms are provided with a water saver.

Condensed water from air conditioners is filtered to the pool for its cooling.

3) Training and information sharing

New engineers are trained (one-day course), and information is shared via every-day meetings and using transmission boards. The wall in the maintenance room is provided with an equipment system drawing to help understand trends of energy consumption in the hotel.

The amount of energy consumption on a day is reported to the staff members and managers on the next day. The engineers and workers hold a meeting once a week for communication.

3.5 The Barriers for the Promotion of Energy Conservation, and Measures Against Those Problems

(1) Problems with energy conservation encouragement

Led by Mr. Sumit as the engineering manager, this hotel deploys excellent energy conservation activities. This success is due to the strong reliance between the hotel owner and Mr. Sumit. That reliance is proven by his word that the owner permits him to do at his discretion.

This may make it able to acquire engineers for further energy conservation encouragement. Younger staff members have come to assume business jobs for the two years following the previous investigation. Although Mr. Sumit is involved actively in training, an important point in the future consists in growing engineers. Furthermore, he is concerned that skilled engineers may be hired by other hotels in Siem Reap where hotels have been constructed increasingly.

(2) Measures for energy conservation encouragement

As described above, anchoring energy conservation activities securely in Cambodia would require that the engineers responsible for actual energy conservation master knowledge for the conservation. Important for Cambodian energy conservation policies is, therefore, to implement an environment for effective training and education.

4. Energy Audit of Angkor Palace Report & Spa

4.1 Outline of Angkor Palace Report & Spa

In Siem Reap which is famous for Angkor Vat, many hotels are being built. Angkor Palace Report & Spa is a high-class resort hotel which opened on January, 2004 (the busy season is October to March and the slack off-season is April to September).

For the audit, Mr. Shanker Rajoo (General Manager), Mr. Chea Chharavuth (Chief Engineer), and Mr. Hang Vannak (Catering Sales Assistant Manager) accompanied us.

(1) Name: Angkor Palace Report & Spa



Figure III-4-1 Exterior of Angkor Palace Report & Spa

(2) Use: Resort hotel

(3) Size: Three floors above the ground, Total floor area: 8,440 m² (including villas)
Number of guest rooms: 74 + 10
Number of villas: 13 with a spa and a ballroom
Another 150 rooms are planned to be built.

(4) Opening: January 2004. Some facilities are still being built and expanded.

(5) Outline of facilities

- 1) Outline of the Building Automation System (BAS)

None. Almost all facilities were manually run by the hotel staff.
Only the number of occupied guest rooms and the oil consumption were recorded and reported to the General Manager and the owner.
In the generator room, the operation time was recorded to determine the overhaul timing of the diesel engines.
- 2) Outline of electrical systems
 - a. Power generation facilities

Generators: Diesel 4-cylinder water cooled, 231/400 V, 50 Hz, 250 kVA (AKSA-AC275) × 1 unit, 500 kVA (AKSA-AC550) × 2 units
One generator is regularly used and the others are standbys.



Figure III-4-2 Diesel Generator

Since the generator power was the only power source, the generators were operated and maintained carefully.

The hotel performed a periodical checking every 250 hours. When the operation time reached 1,500 hours or 6,000 hours, the generators were overhauled by a professional (AKSA Cambodia, Co., Ltd.).

The three generators ran in turn to make even the operation time of each generator. The fuel was purchased from Caltex Co., Ltd. three to four times a month and stored in a 21,000-liter fuel tank. When we were on the way to the generator room, we saw direct burial installation work of cables and asked the reason. The answer was they added backup cables which were thought to be necessary according to the cable problems experienced in the past.



Figure III-4-3 Generator Room

- b. Low-voltage power distribution facility
 - Three-phase, four-line, 400 V
 - For the central section and wings: 13 main feeders and 19 subfeeders
 - For the villas: Five feeders
- c. Lightings
 - Indoor and outdoor lightings
- d. Elevators
 - For carrying people: 7.5 kW × 1 unit
- 3) Outline of air-conditioning systems
 - Air cooled packaged air conditioners: About 100 units in total
 - Details: For guest rooms: 2 HP × 74 units
 - For villas: 3.5 HP × 5 units
 - For the restaurant: 5 HP × 2 units
 - For the ballroom: 5 HP × 6 units
 - For the gym: 3.5 HP × 1 unit
 - For the massage room: 2 HP × 2 units
- 4) Outline of sanitary facilities
 - a. Water supply system
 - Well water lift pumps: 60-m or greater head × 2 units
 - Water processing facilities: Three units, 1.5 kW (2 HP) pump for the facilities × 6 units
 - Water receiving tank: 100 m³ × 1 unit, Lifted water tank × 2 units,
 - Underground tank × 2 units



Figure III-4-4 Water Processing Facility

- b. Hot water supply system: Hot water tanks heated by electric boilers:
300-liter \times 2 units, 200-liter \times 2 units
- c. Steam generator: Electric steam generator \times 1 unit
- d. Laundry drier: Electric heater \times 2 units

4.2 Analysis of Current Status

(1) Facility management system

The hotels in Cambodia can be divided into two main categories: those built by the international capital and those built by the local capital. Angkor Palace Resort & Spa is owned by a Cambodian.

Mr. Shanker Rajoo, General Manager, is from Malaysia. The general managers and chief engineers for high-class hotels are the people with experiences in foreign countries. The demand for such personnel is high but the resources are short. Since the head hunting is quite common way to get such personnel here, the post of the sub-chief engineer of Angkor Palace Resort & Spa was vacant at the time.

Mr. Hang Vannak of Catering Sales department seemed to be responsible for the assistant jobs for the General Manager, including planning, administration and financing and energy cost management, etc.

The facility operation was managed by the Engineering section (three shifts for 21 people).

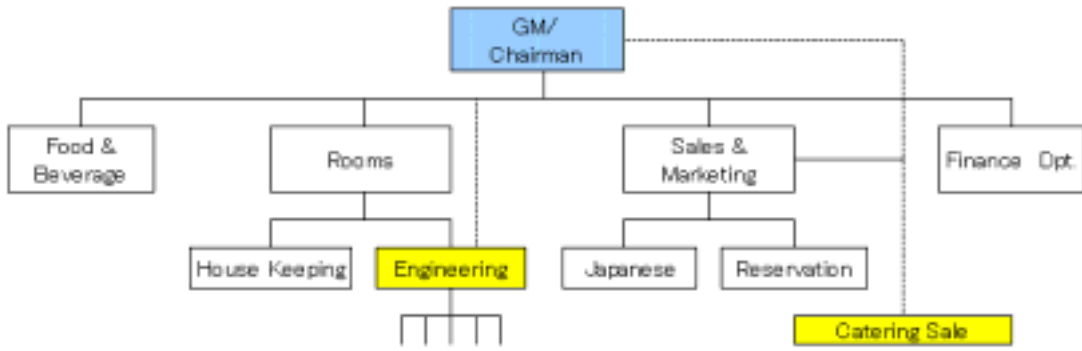

Figure III-4-5 Hotel Management System

(2) Energy consumption

The energy used in the hotel was the generated power only. This section describes the fuel used for the generators and electric energy.

1) Monthly fuel consumption

The fuel consumption is increasing steadily since the hotel opened not long ago and some facilities are still being built and expanded.

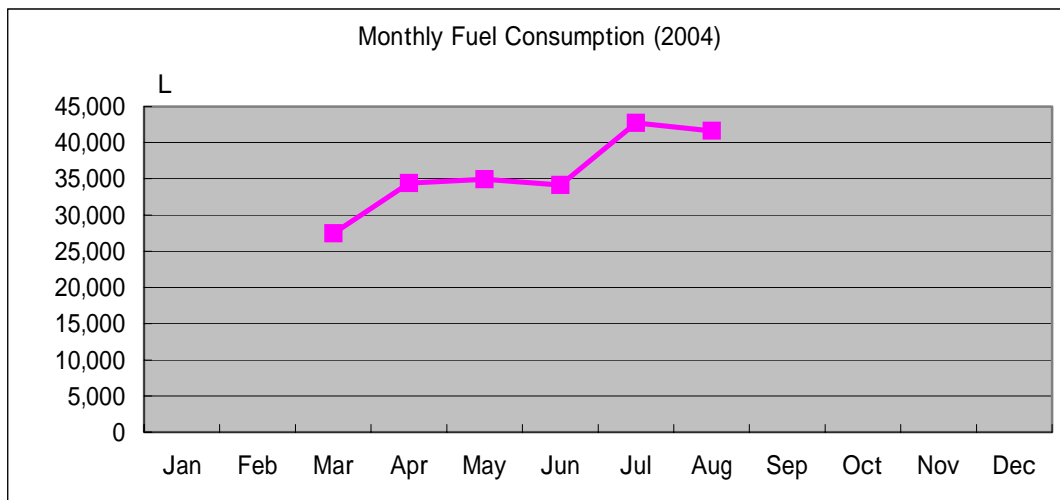

Figure III-4-6 Monthly Fuel Consumption

2) Daily fuel consumption

The consumption varies significantly from 3,928 kWh to 5,657 kWh.

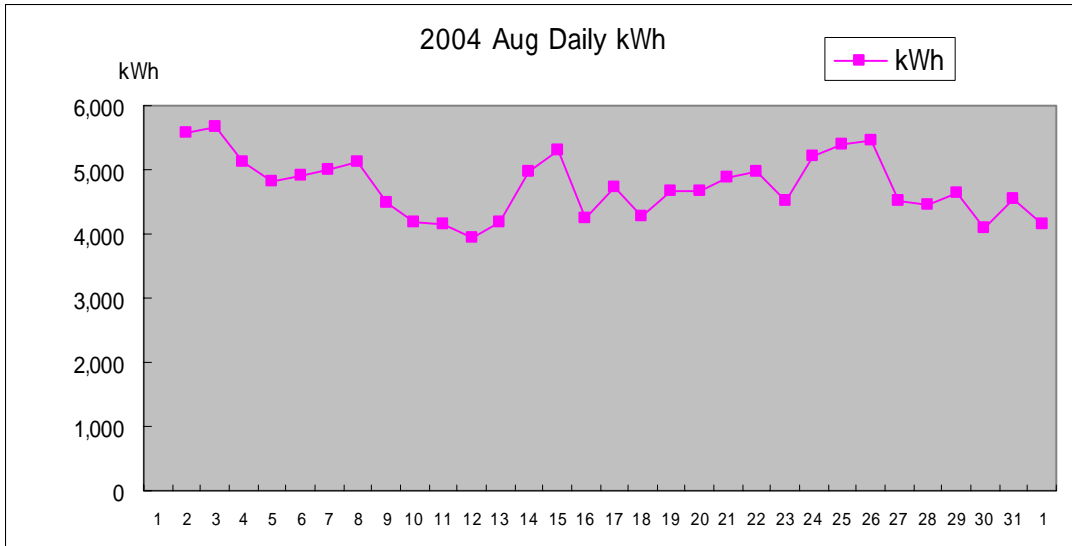

Figure III-4-7 Daily Fuel Consumption

3) Hourly fuel consumption

The following figure shows the electric energy consumption on the day with highest occupancy rate (96%) and the day with lowest occupancy rate (24%) in August. The big difference of the two days is occurred in the evening and the night. This is probably caused by the difference in the air-conditioning load.

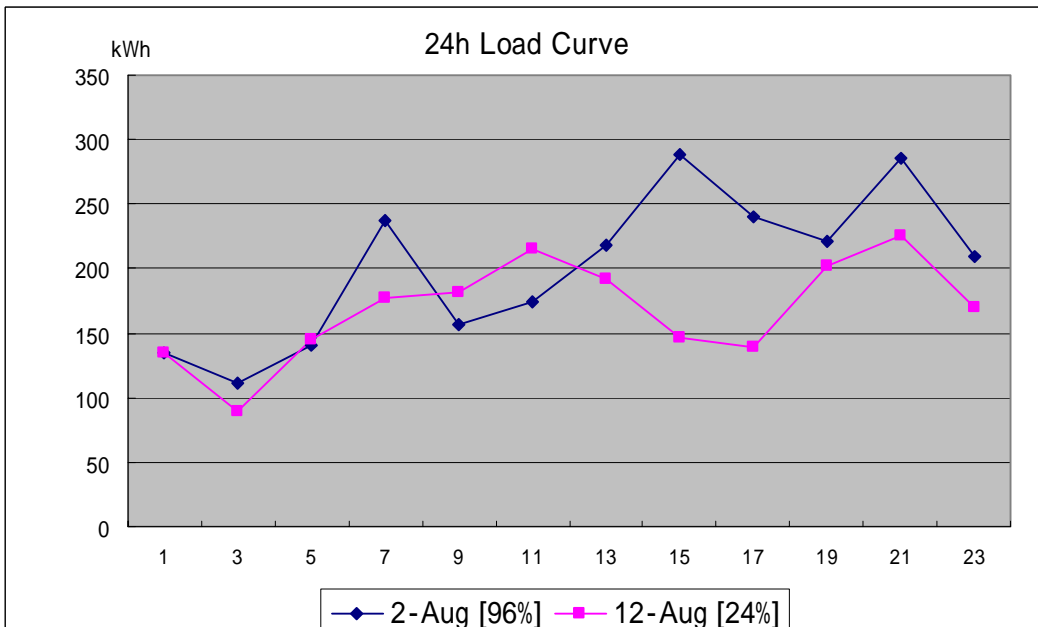

Figure III-4-8 Hourly Fuel Consumption

(3) Evaluation of energy consumption

1) Evaluation of electric energy consumption

In the resort hotels, the floor area per room is larger than that of hotels used mainly for business. Therefore, the “per GFA” may not be the most suitable index for energy efficiency but we usually use it for comparison.

The Energy Efficiency Index (EEI: annual electric energy consumption per index unit area) of the hotels in Indonesia was 300 kWh/m²/y on the average (the value was obtained from a report in the workshop held on September 16 in Jakarta).

Since Angkor Palace Resort & Spa is less than one-year old, we multiply the nearest data (August) (average of the day's total: 4,735 kWh) by 365 to determine the annual electric energy consumption (1,728,375 kWh).

$$EEI = 1,728,375 \text{ kWh} / 8,440 \text{ m}^2 = \text{approximately } 204.8 \text{ (kWh/m}^2\text{)}$$

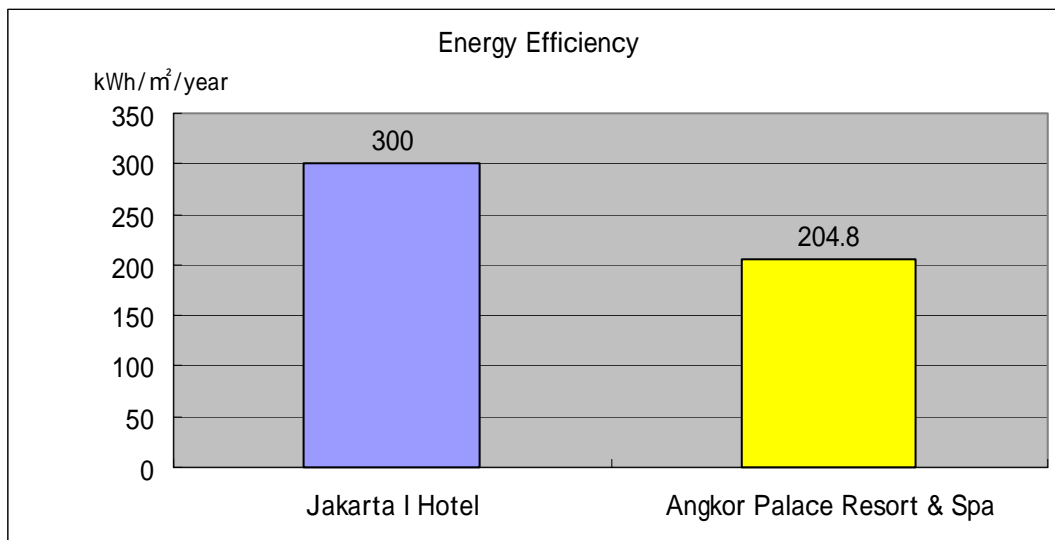

Figure III-4-9 Electric Energy Consumption per Floor Area

2) Fuel consumption intensity per guest room

Angkor Palace Resort & Spa managed energy based on the fuel consumption per guest room rather than the energy consumption per floor area of the building (EEI).

This is probably because the energy consumption per guest, which is part of cost, is easier to understand as management data rather than the energy efficiency ratio.

The following figure shows the changes of the fuel consumption intensity per guest room in July, and August 2004 based on the received data.

The bar graphs show the number of guest rooms used per day. The yellow line graph shows the fuel consumption per guest room. The pink line graph shows the total fuel consumption of the day. The electric energy consumption does not change very much day to day. However, the electric energy consumption

intensity changes greatly every day. This is because the number of occupied guest rooms changes every day.

Figure III-4-10 Daily Fuel Consumption and Fuel Consumption per Guest (July 2004)

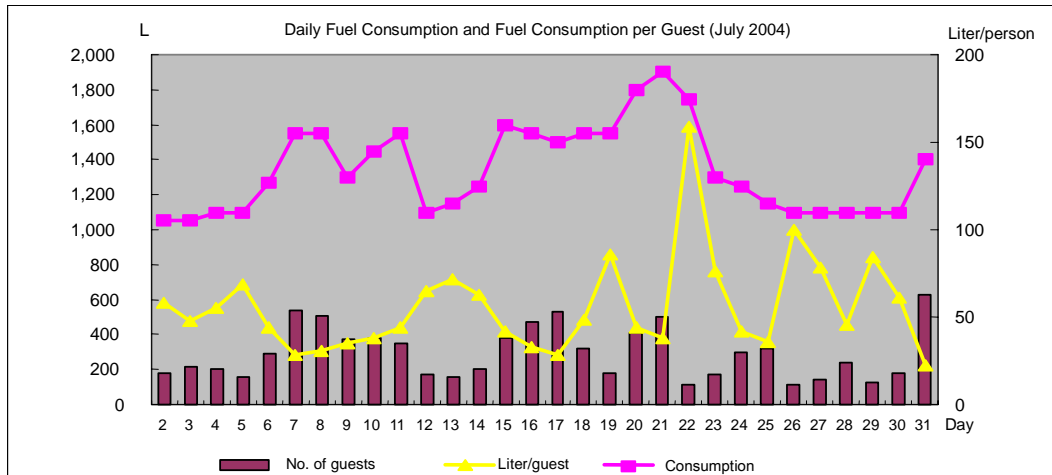
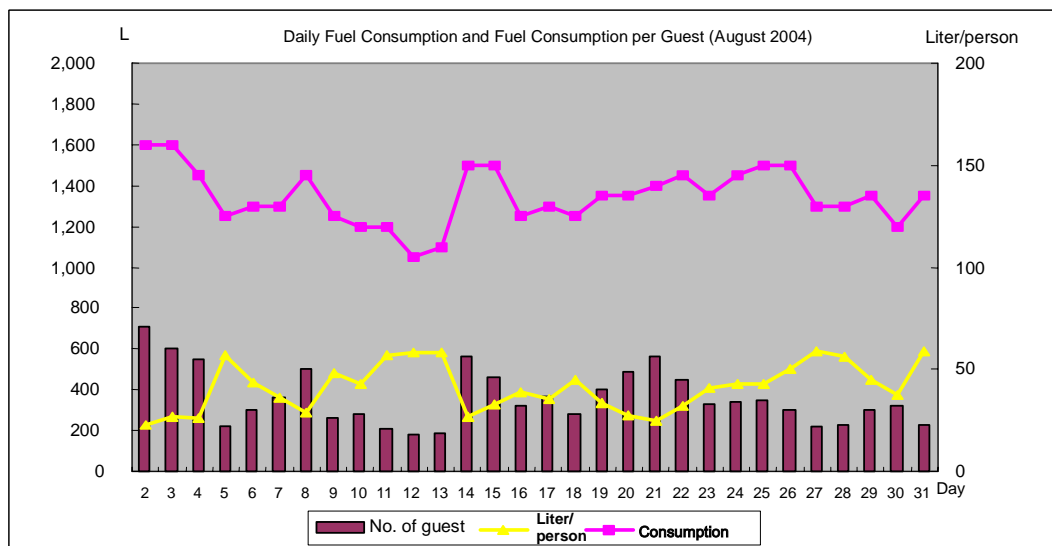

Figure III-4-11 Daily Fuel Consumption and Fuel Consumption per Guest (August 2004)



3) Considerations

The electric energy consumption intensity per floor area of Angkor Palace Resort & Spa is less than the Indonesian average by 30%. This is probably because the hotel has many corridors and open space since it is a resort hotel. The energy consumption per guest room differs depending on the number of guests.

The fuel unit price increased rapidly in Cambodia. In June, the price was

0.4375 US\$. In the middle of August, the price was 0.4975 US\$, which is a 13.7% increase in 2.5 months. The fuel cost per guest (monthly average) reached 18.8 US\$. Energy conservation was a major concern in management as well.

However, as the control item for the management was only the fuel consumption (daily total) which the entire energy cost. The recorded data was insufficient to determine what needed to be done to perform the energy conservation operation. Although you could read the measurements such as voltage, power factor, frequency, and electric power on the LCD panel attached to the operation control board on the generator, these measurements were not recorded.

To reduce the energy cost and improve the reliability of the supply of electric power, the hotel was making every effort to maintain and operate the generators by assigning two engineers to constantly monitor the operation and perform routine maintenance. Professional outsourcing was also brought in periodically to maintain the generators.

The appropriate management and checkup of the generators seemed to prevent failures and inefficiency.

4.3 Points for Improvement and Expected Effects

This section describes the points for improvement and the expected effects based on the walk-through survey of the building and the analysis of the energy data.

(1) Improvement of the power factor

The power factor was 95.8% when measured on the panel meter on the control board of a generator. The power factor can be improved to 100% by adding an adequate capacitor, which reduces the 4.2% loss. This reduces the fuel by 72,592 kWh or 10,235 US\$.

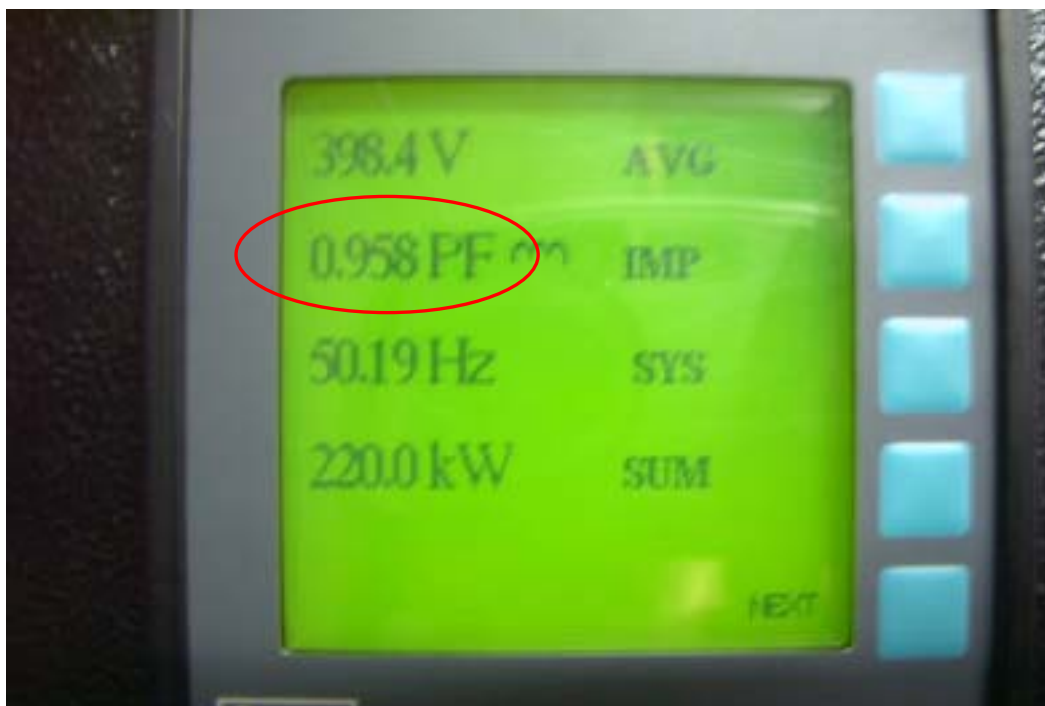

Figure III-4-13 Power Factor Displayed During Diagnostics

Table III-4-1 Energy Conservation Effects Due to the Improvement of the Power Factor

Power Generation & Consumption				
kWh/Day	Day/y	kWh/y	Reduction	kWh
4,735	365	1,728,375	4.2%	72,592
	/kWh	US\$/y		US\$
	0.141	243,701	4.2%	10,235

(2) Measurement of the electric energy consumption per feeder

By attaching a watt-hour meter on each feeder or by measuring the electric energy consumption every hour using a handheld watt-hour meter, they can determine whether the electric energy is used efficiently or the generator is running efficiently. By implementing these measures, energy efficiency may improve by a few percent.

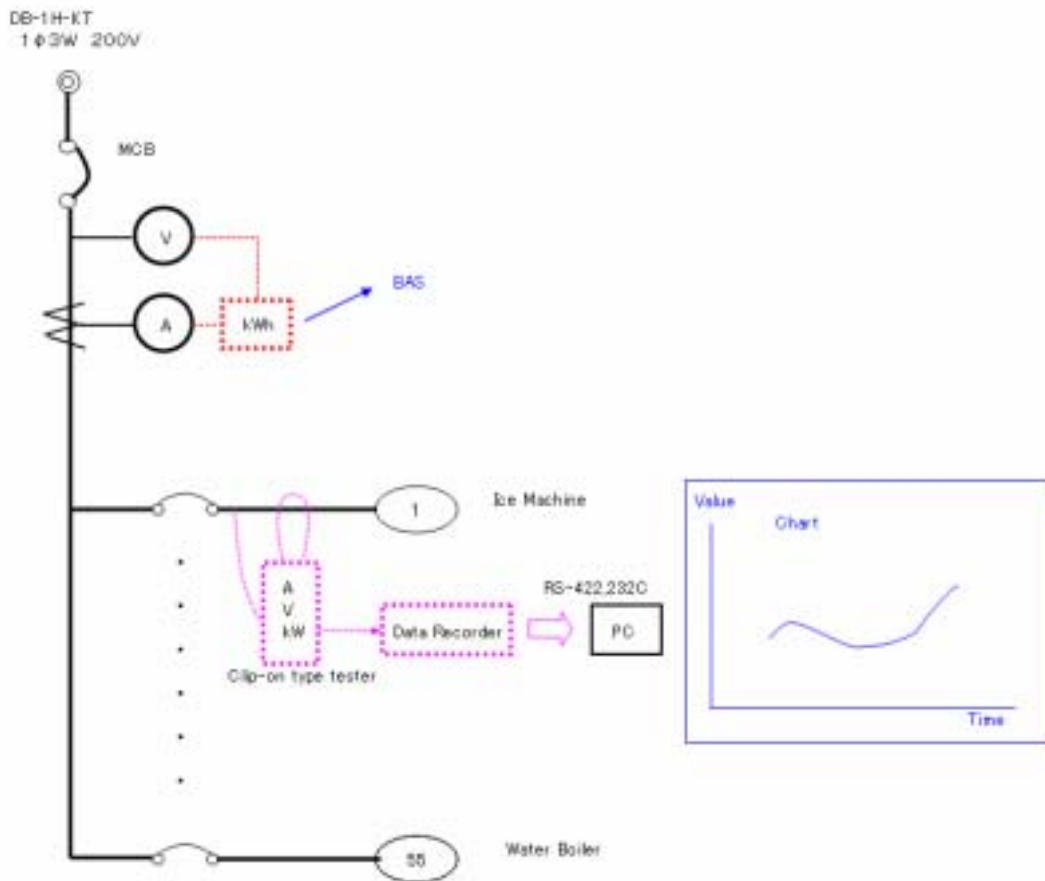

Figure III-4-14 Concept of Measuring the Electric Energy Consumed by a Feeder

5. About the Result of the Workshop

5.1 Outline

We are not sure about the accurate number of participants but it was about 60 people. The workshop was successful with many questions and discussions.

The workshop was held in Phnom Penh. Mr. Ith Praing, Secretary of State of the Ministry of Industry, Mines and Energy (MIME) and other top officials such as Dr. Sat Samy (later promoted to the post of Under Secretary who was then working for Mr. Praing) participated. Just before the workshop, as we were informed that Cambodia had only one presentation by the Chief Engineer of Sofitel Royal Angkor. Therefore, we decided to report on the survey results on both Sofitel and Angkor Palace Resort & Spa. Although the preparation was difficult, the presentation was successful, and appreciation was expressed to the experts.

Thailand, Malaysia, and Singapore gave five presentations, which were all good. We, as well as the Cambodians, learned a lot from those presentations.

5.2 Discussion on the Survey Results (Barriers in Implementing and Disseminating Energy Conservation Measures and Countermeasures)

We reported the results of the energy audit on Angkor Palace Resort & Spa in Siem Reap. We also reported the results of the survey on Sofitel Royal Angkor Hotel to the Maintenance Manager who came to the workshop in Phnom Penh.

The General Manager of Angkor Palace Resort & Spa was enthusiastic, made some decisions about the future improvements, and gave us comments during our report.

The details are not discussed here since they are described in other sections in this report. We asked Mr. Vuthy of MIME to implement the future follow-ups.

5.3 Policy on Creating the Technical Directory

We explained the basic idea and suggested some elements of the Technical Directory at the workshop and obtained approval from the participants. The features are as follows:

- Include the technologies that are suitable for Southeast Asia and those that have been recommended by Japanese experts or those actually used in Japan.
- Include successful examples of the above.
- Prepare the basic format that can be easily expanded or changed in the future based on the above.

We asked the Cambodian side at least to prepare successful examples.

Workshop Program in Cambodia

08.00 – 08.30 Registration

08.30 – 08.35	Welcome Remarks	Mr. Ith Praing, Secretary, MIME
08.35 – 08.40	Opening Statement	Mr. Yoshida Kazuhiko, General Manager, ECCJ
08.40 – 08.45	Opening Statement	Dr. Weerawat Chantanakome, Executive Director, ACE
08.45 – 09.00	Coffee Break & Photo session	
Session I :	Policies and Programs on Energy Conservation	
09.00 – 09.20	Energy Conservation Policy and Programs of Cambodia	Dr. Sat Samy, Under Secretary, MIME
09.20 – 09.40	Japan’s Energy Conservation Programs	Dr. Yoshida Kazuhiko, ECCJ
09.40 – 10.00	Summary of Barriers and Measures & Question and Answer	
Session II :	Energy Conservation Best Practices for Buildings in Cambodia	
10.00 – 10.20	Building No. 1 in Cambodia	
10.20 – 10.40	Building No. 2 in Cambodia	
10.40 – 11.00	Building No. 3 in Cambodia	
11.00 – 11.30	Question and Answer	
Session III :	Energy Conservation Best Practices for Buildings in ASEAN Countries	
11:30 – 12:15	Central Academic Shinawatra University Building (Thailand) Dr. Soontorn	
12.15 – 13.30	Lunch Break	
13.30 – 14.15	Alexandra Hospital Building (Singapore)	Mr. Stewart
14.15 – 15.00	University Teknologi Malaysia (UTM)	Prof. Dr. K. S. Kannan
15.00 – 15.30	Coffee Break	
15.30 – 16.15	Ministry of Education Building (Singapore)	Mr. Lawrence Koo
16.15 – 17.00	Discussion	
17.15 – 17.30	Summary: Barriers and Measures	
Session IV :	The Way Forward: Dissemination Procedure	
17.30 – 17.45	Development of Technical Directory	Mr. Kazuhiko Yoshida, ECCJ
17.45 – 18.00	Development of Local Database/Benchmark/Guideline by ECCJ Mr. Kazuhiko Yoshida, ECCJ	
18.00 – 18.15	Closing Statement	

5.4 Discussion for Establishing the Database, Benchmarks, and Guidelines in Cambodia

In the workshop, we explained the basic idea including how the system worked. The activities must be in cooperation with the ASEAN Benchmarking being performed by Singapore and other ASEAN countries. However, it is important that they should plan and establish the database, benchmarks, and guidelines for Cambodia must be planned and established first.

The Japanese experts suggested the idea that the energy efficiency of energy consumption per guestroom instead of energy consumption per floor area should be used as the energy intensity. We made this an official suggestion from Japan side and discussed how this energy intensity should be used in future activities.

IV. Thailand

1. Activity Overview

In Thailand, we only carried out a follow-up survey in EGCO TOWER as a business building, and did not perform an energy audit on another new building. In this country, we also held a workshop.

The following gives the participants and task records.

Participants from the International Engineering Department of the Energy Conservation Center, Japan (ECCJ)

- Kazuhiko Yoshida (General Manager)
- Akira Kobayashi (Technical Expert)
- Yohichi Kita (Technical Expert)

Task records

Date		Description
October 31	Sunday	Left Japan, and arrived at Bangkok.
November 1	Monday	Carried out a follow-up survey on EGCO Tower.
November 2	Tuesday	Carried out a follow-up survey on EGCO Tower.
November 3	Wednesday	Arranged the results of the survey.
		Reported the results of the follow-up survey at EGCO Tower.
November 4	Thursday	Made discussions with the relevant DEDE members (to generate databases, benchmarks and guidelines, and create a technical directory).
November 5	Friday	Held a workshop.
November 6	Saturday	Holiday
November 7	Sunday	Left Bangkok for the Philippines.

We carried out a follow-up survey at EGCO TOWER, a business building that was subject to an energy audit in December 2001. The follow-up survey consists of:

- pre-sending a questionnaire;
- letting the responsible building staff member report the achievements of taking the building's own measures and measures for more effective energy conservation recommended particularly by Japanese experts in the past;
- receiving latest data on energy management; and
- performing a site survey for confirmation.

This building is characterized by very low energy consumption per unit floor area, or for effective energy conservation. Only a very small number of people, however, work in the building. Our evaluation review is done based on this fact.

The workshop was attended by about 45 persons including Ms. Pranee, a vice departmental manager of the DEDE, and Mr. Pravit, an executive director. Very active discussions were made in the workshop, which provided a positive chance for the building's staff members to exchange comments and information.

2. Recent Trends of Energy Conservation and Building Management in Thailand

2.1 Recent Trends of Energy Conservation in Thailand

The following gives recent trends of energy conservation presented by the ACE.

Overall Energy Situation and Policy

Energy is one major driving force for the growth of a country. Each year Thailand spends over 800 billion bath for energy. More importantly, 48% of total energy supply is imported, marking an increase of energy imports around 8% annually. In addition the oil price fluctuation in recent years has made apparent the importance of sustainable energy development of our country.

With the oil price volatility, Thailand has been in a vulnerable situation. Increase in oil prices usually affects commodity prices, and there is a risk of oil supply disruption. However, we can turn the crisis into opportunity -- the opportunity to review the national policies related to both building and industrial sectors, underscoring the ways to create added value of agricultural products as well as strategies to secure energy supply and to solve problems on oil shortage or oil price hikes. In order to ensure the national energy supply security and sustainable energy development, Thailand's energy policy has placed greater emphasis on **the efficient use of energy and the development of renewable energy resources** by enacting Energy Conservation Promotion Act and establishing Energy Conservation Promotion Fund.

Recognizing the significance of sustainable energy, Thai government promulgated Energy Conservation Promotion Act since 1992. The Law provide regulatory framework for big energy-consuming facilities to improve their energy efficiency. Energy building codes have been set to constrain the overuse of energy by prohibiting poor heat transfer materials, poor lighting design, and poor air conditioning efficiency.

Financial support is crucial for the promotion of the efficient use of energy. In 1995, Thai government established the ENCON Fund for supporting a great variety of projects, ranging from projects on improvement of energy efficiency by using proven technologies; projects on the demonstration and dissemination of renewable energy technologies; research and development projects; to projects on enhancing a market of renewable energy technology equipment as well as projects on training and public relations. Its revenues are derived from the premium rates imposed on domestically sold petroleum.

In order to achieve greater tangible outcomes of the energy conservation policy, the government has recently approved the "**Strategic Energy Conservation Plan for Competition**". The Plan comprises four main elements, namely: energy conservation, renewable energy utilization, human resources development and public awareness campaign. Ambitious targets have been set to lessen the ratio of energy consumption growth to GDP growth from 1.4 to 1.0 by the year 2010.

2.2 Recent Trends of Building Management in Thailand

The following gives recent trends of building management presented by the ACE.

Energy Conservation in Buildings

Energy conservation in building sector is one of the main focuses since its energy consumption accounts for over 20 percent of total energy demand and continues to increase quite rapidly. In hot and humid climate like Thailand, enormous amount of energy is required to provide comfort to building occupants. Air conditioning, ventilation, pumping and lighting entail a big chunk of electricity. It is obvious that improving energy efficiency of buildings will, no doubt, slim down the size of energy bills, not only for building owners but also for the country.

Substantial amount of energy savings for buildings can come from a good design. Effective use of environment and surroundings to cool down the buildings will reduce significant amount of air conditioning load and thus reduce the energy to be consumed. Appropriate insulation and well-designed shading will definitely lower the transfer of heat into the buildings. In addition, successful utilization and distribution of natural lighting can brighten up the workplace with little or no use of energy.

The strong relationship between building design and energy needs proves the importance of Green Architecture. Research and development for new materials and new techniques must continue to improve the way we design and build. Sharing experience and transferring advanced and appropriate technologies will build up our knowledge as well as strengthen our capacity in the area of Green Architecture.

Thai government is also in a process of drafting new Building Energy Code which will be more stringent, but yet practical, with an aim to an end result of building performance. The new code will have prescriptive requirements and overall requirement. Building architects are allowed to choose whether to comply with prescriptive or overall requirement. This will give flexibility to be more creative on the use and integration of energy conservation techniques and materials for overall building performance. The code is expected to be in effect by 2004.

There are many incentive and technical assistance programs provided to help building owners and operators to improve their energy efficiency. Revolving fund (RF), for example, provides a soft loan for investment that aims to reduce energy consumption in buildings and industry. The RF program help reduce the cost of capital offering a fixed interest rate of less than 4 percent over the length of loan period (less than 7 years). Another program worth mentioning is the program called "Energy Conservation through Cooperative Efforts". The program provides technical experts to help facilities establish their energy conservation teams and supervise them to develop energy conservation measures for their respective industry / building. Mainly the program will target no-cost to low-cost measures and some routine housekeeping to minimize the wasteful use of energy.

Tax incentive program is also under development. Ministry of Finance, Ministry of Energy and Ministry of Industry are working together to create a system to offer a reduction of cooperate income tax based on their energy savings. The rational of performance-based incentive is that energy savings consequently will transfer to profits of the company and these profits should not be applicable for taxation. It is still under discussion the way to measure the energy savings that give accurate results at some degree without troubling business practices.

Conclusion

Energy is essential for economic development. Energy Conservation in building sector can play an important role for the sustainable development of the Country. Energy conservation is the responsibility of everyone - from government to general public, from architects to building owners, from building operators to building occupants. As all elements, policy, financing mechanisms, networking, technical & institutional capacities, and public awareness are interrelated, sustainable energy would be difficult to achieve if only some of these elements, not all, are promoted.

3. Follow-up Energy Audit on EGCO TOWER

3.1 EGCO TOWER Overview

- (1) Name of the building: EGCO TOWER

Figure IV-3-1 EGCO TOWER Appearance



- (2) Located at: 222 Moo 5, Vibhavadi Rangsit Road, Tungsonghong, Laksi, Bangkok Thailand
- (3) Application: Office (used by the company herself)
- (4) One story under and 18 stories above the ground
- | | |
|---------------------------|---|
| Total floor area: | 33,587 m ² (including the parking space) |
| Air-conditioned area: | 12,430 m ² |
| Area not air-conditioned: | 7,532 m ² |
| Parking area: | 13,625 m ² (First to eighth stories) |
| Area used actually: | 15,709 m ² (Applied as GFA to calculate energy use efficiency) |
- Number of working persons in it: About 200 (This value is very low. A Japanese similar office building contains no less than 600 persons.)
- Working hours: 8:00 to 17:00 (Monday to Friday)
- (5) Constructed in: May 1998

- (6) Owned by: EGCO (Electricity Generating Public Company Limited)
- (7) Building management: Entrusted to Jones Lang LaSalle Inc. (The previous audit was entrusted to First Pacific Davies Inc.)
- (8) Features of the building

This building is of a hexagonal shape to minimize the invasion of solar rays. The curtain wall and glass are characterized by high thermal insulation. (Some walls are made of aluminum alloy plates or three layers of laminated glass providing high thermal insulation.) Natural ventilation, and planting on the roof and surroundings of building help reduce the ambient temperature. This building is designed by taking thorough energy conservation into account.

Figure IV-3-2 Typical Story's Plan (Divided Illuminated Zone)

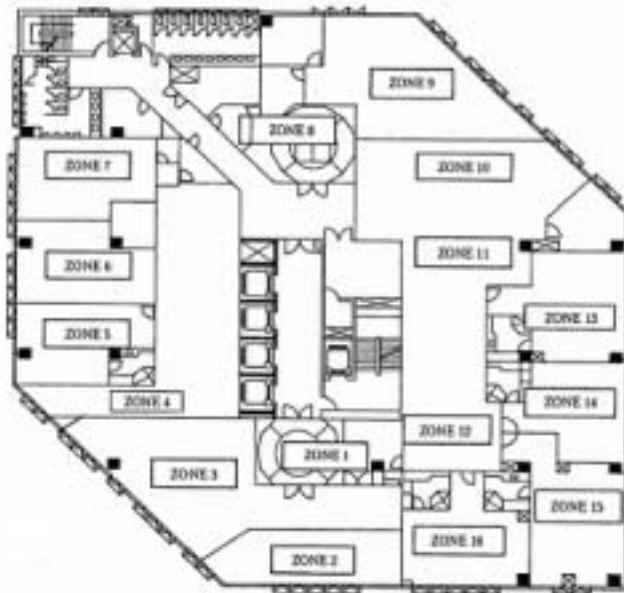

Figure IV-3-3 Thermal Insulation System

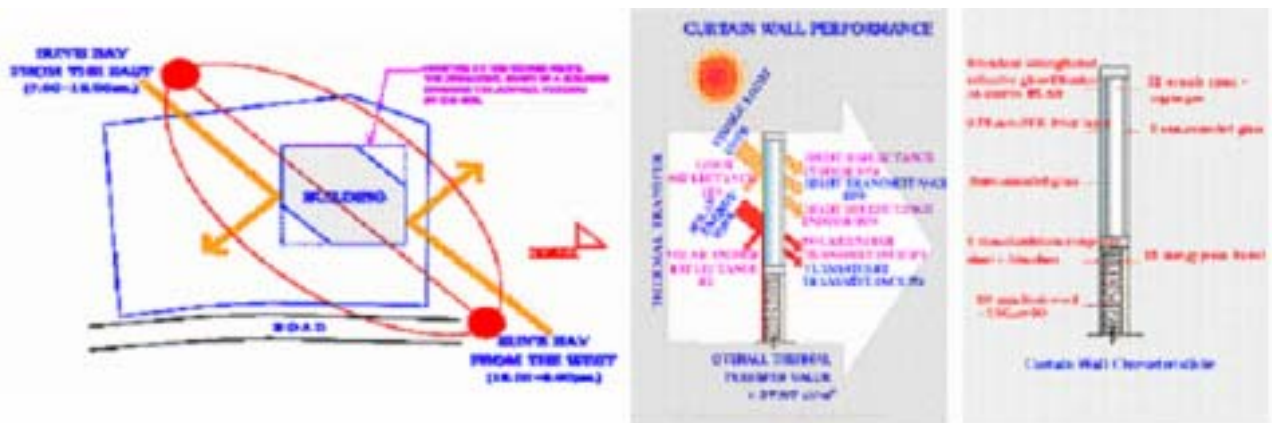

Figure IV-3-4 Natural Ambient Temperature Reduction



(9) Equipment overview

1) Building automation system (BAS)

Supports schedule control, running monitoring, trend display, and other functions. (This system is equipped with no data logging function.)

2) Electric equipment

a. Substation

Three transformers (1,600 kVA (24 kV/416 V) (including one spare)

Demand control: 500 kW (Mean electric power)

b. Illumination capacity

Room: 291 kW

Outdoor: 13 kW

c. Elevators

Four elevators for guests (24 kW)

Two elevators for personnel and baggage (24 kW and 7.5 kW)

One elevator for wastes (4 kW)

One dumb waiter (1.5 kW)

- 3) Air conditioning
- a. Chillers
 - Three turbo chillers (250 RT (172 kW))
 - One auxiliary screw chiller: 150 RT (105 kW)
 - b. Additional chilling equipment

	For the turbo chiller	For the screw chiller
Cooled-water pump	22kW × 3	15kW × 1
Cooling water pump	18.5kW × 3	11kW × 1
Cooling tower	7.5kW × 3	4kW × 1
 - c. Air conditioners
 - AHU: 11kW×3, 7.5kW×5, 5.5kW×9, 4kW×5, 1.5kW×4
 - FCU: 3.7kW×9
 - Four packaged air conditioners (PAC): 20 kW
 - Three heat exchangers (Fresh-air intake fans): 15 kW
 - One heat exchanger (Pressured fan): 11 kW
 - d. Six ventilating fans: 28 kW
 - 73 ventilating fans: 11 kW
- 4) Sanitation
- | | |
|----------------------|---|
| Water reservoir | 389 m ³ |
| Top water reservoir | 158 m ³ |
| Water supply pump | 37 kW(330GPM × 295ft) |
| Pressured pump | 5.5 kW |
| Water discharge pump | 10 kW (Four pumps), a. Water supply equipment |

3.2 Outlined Results of the Previous Audit

- (1) The audit was carried out on December 12 (Tuesday) to 14 (Thursday), 2000.
- (2) Diagnosed by: Energy Conservation Center, Japan
 International Engineering Department
 Yasuhumi Serizawa (General manager)
 Yasuo Furusawa (Technical expert)
- (3) Outlined results of the audit
 - 1) The chiller and the water supply pump have problems caused by excessive capacity. Only one chiller (250 RT) is enough to fulfill appropriate requirements. Three chillers are unnecessary. One chiller (250 RT) provides total cooling capability of 23 kcal/h square meters. The capability can be converted into a target cooled area of 51 kcal/h square meters. One chiller can totally cover very low cooling load of 23 kcal/h square meters. This building is excellent in energy conservation performance. No more than 1.3 hour operation of the water supply pump (rated at 37 kW) a day can fulfill appropriate

requirements. A required daily volume of about 100 cubic meters of supply water can be covered by a pump rated at 7.5 to 15 kW. Currently, the pump is run only during the night when an inexpensive electric power charge is applied, causing no significant problems.

- 2) The additional chilling equipment is run under full capacity. The cooled water pump is driven by a motor which is rated at 22 kW and receives input power of 23.8 kW. The cooling water pump is driven by a motor which is rated at 18.5 kW and receives input power of 19.2 kW. This data tells that the cooling water pump is not provided with sufficient capacity in comparison with Japan.
- 3) In the lighting, enough energy conservation is implemented. For example, the lighting area is sectioned and day light is utilized positively. The lighting is 600 to 700 lux in a light area, being considerably lower than in Japan. The lights of the unused rooms are turned off nearly completely.

(4) Proposed measures for energy conservation

1) Reduction of the period of chiller operation

The cooled water pipe contains a large volume of water (30 cubic meters possibly equivalent to 50 to 100 RT). This requires a pre-cooling period for decreasing the temperature of water in the pipe that has been increased during night. Although the hotel is opened at 8:30, the chiller is started at 5:30. This start is too early. The chiller should be started one hour to one hour and a half later than the present starting time. Since the cooled water in the pipe has accumulated cooled heat, it is recommended to reduce cooled water temperature by full chiller operation in advance before closing of the building, and using such cooled water completely to the temperatures of 15 to 18°C to get 300 Mcal (30 cubic meters × 10°C). By application of this method, the chiller could be stopped nearly one hour earlier. If the period of chiller running could be reduced by two hours at the time of the start and stop, we would get:

$$\text{Amount of energy conservation} = (95 \text{ kW (chiller)} + 50 \text{ kW (additional chilling equipment)}) \times 2 \text{ hr/d} \times 20 \text{ d/m} = \boxed{5.8 \text{ MWh/m}}$$

- 2) Increasing the (room) cooling temperature (in summer) by 2°C (from 24 to 26°C) would reduce the energy relating to the thermal source by 20 percent. We would get:

$$\text{Amount of energy conservation} = 48.5 \text{ MWh/m} \times 0.2 \text{ (reduction of 20 percent)} = \boxed{9.7 \text{ MWh/m}}$$

- 3) Turn-off of lights during a lunch break

Turn-off of lights during a lunch break would lead to a reduction in lighting power, as well as in the cooling load. Turn-off of 50 percent of room lights for one hour during a lunch break would provide:

$$\text{Amount of energy conservation} = 130 \text{ kW} \times 0.5 \text{ (50 percent)} \times 1 \text{ hr/d} \times 20 \text{ d/m} = \boxed{1.3 \text{ MWh/m}}$$

Taking above measures 1), 2) and 3) would result in a reduction in power

consumption of 16.8 MWh/m. This value is equivalent to 12.5 percent of energy conservation against the total energy consumption of 134.2 MWh/m. In addition, as the charge of electric power use is 6.55 yen/kWh, the hotel could reduce costs by about 1.30 million yen per year.

4) Suitable voltage setup

A somewhat higher voltage is set since the occupancy rate of the building is about 60 percent. The transformer tapping or the capacitance (in particular, for lighting) should be adjusted to keep a suitable voltage value. Furthermore, this adjustment would contribute to more effective energy conservation.

5) Demand control

The trend chart (Figure 6) for transformer 2 (MDB1B) on December 7, 2000 tells that the maximum load occurs owing to the elevator load during a lunch break. In such a case, the chiller should be fully run before a lunch break to reduce water temperature (in the pipe). It should be stopped during a lunch break of 30 to 40 minutes when the maximum load occurs. And only the cooled-water pump should be run, (and in some cases, some of the air conditioners should be stopped). For implementing this proposal, they should make a trend chart for transformers 1 and 2 and check their loads.

6) Control the number of elevators to be run

The building elevators are run most frequently during office-going and office-leaving, and a lunch break. In the other time zones when the elevator are used less frequently, the number of running elevators should be reduced to enable more effective energy conservation.

7) Reduction in night loads

According to the trend chart, the situation of night loads should be examined to stop the useless loads as much as possible. Reducing night loads would contribute to more effective energy conservation even if their capacity (kW) is low.

3.3 Results of Implementing Previous Proposals

(1) EGCO Ltd. overview

EGCO (Electricity Generating Public Company Limited) was founded by EGAT (Electricity Generating Authority of Thailand) in May 1992 as the first independent power producer (IPP: Independent Power Producer) in Thailand. This power generating subsidiary is owned completely by EGAT. EGCO purchased two power plants (rated at 2,056 MW) from EGAT, and invested in domestic and overseas power generation projects. It is the biggest IPP in Thailand, providing power generation capacity of 2,800 MW. EGCO has been involved actively in electric power development in overseas countries such as Laos. It is one of the most profitable firms in Thailand, with sales being 15 billion bahts (about 42 billion

dollars) and the profit being 6 billion baths (about 16 billion dollars).

(2) Interviewees: EGCO

Ms. Prapaporn Virojsaengtong (Vice President – Administration & Services)

Mr. Saksit Suntharekanon (Assistant Vice President - Engineering)

A few staff members of Jones Lang LaSalle as the appointed management firm

(3) Implementation of the previously proposed items

We were surprised that 100 percent of the previously proposed items except the unnecessary ones had been implemented. The following describes the contents of this implementation.

1) Reduction in the period of chiller running

Implemented. The running period has been reduced from 13 hours (5:00 to 18:00) to 11 hours (6:00 to 17:00).

2) Increase of 2°C in the set cooling temperature

Implemented. This temperature has been increased from 24 to 25°C by one degree C.

* We had recommended that the temperature be increased from 24 to 26°C by 2°C.

3) Turn-off of lights during a lunch break

Implemented. The lighting schedule is controlled automatically by the BAS system. The lighting service time in the building is 6:45 (8:00 (office time)) to 19:00.

4) Suitable voltage setup

This is not required (because a suitable voltage has already been set).

5) Demand control

Implemented. (Reduced gradually from the first stage.) Changing the periods of chiller and pump running has allowed the monthly mean peak demand to be reduced from 560 kW to 460 kW. Should a peak demand of 500 kW be exceeded, the demand is so controlled as to cut lower-priority loads (including fountains, water treatment pumps and exhaust fans).

Figure IV-3-5 Demand Reduction

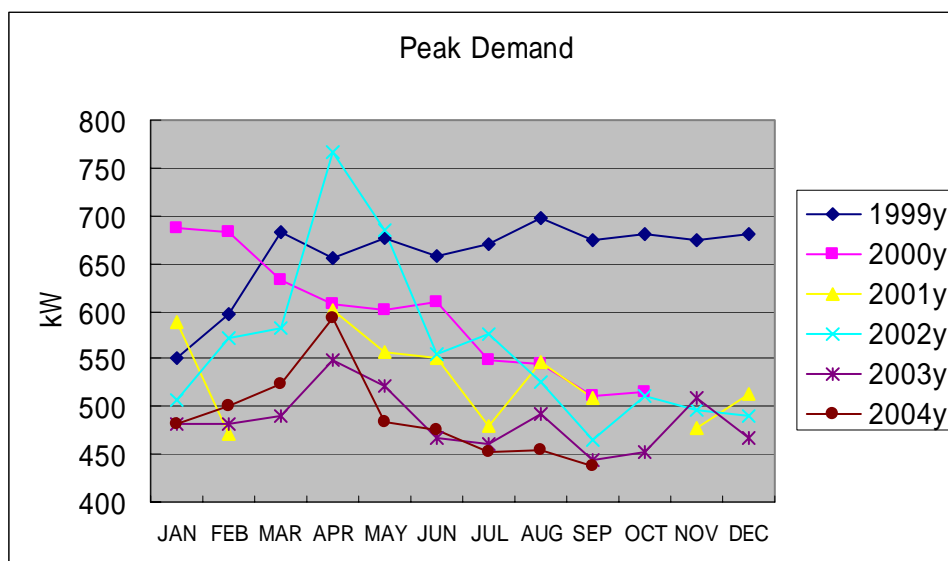

- 6) Control over the number of running elevators
This is not required. The EGCO Tower's elevators are group-controlled, with power consumption minimized.
- 7) Reduction in night loads
Implemented.
Example: A yoga class held on Monday evening in each week is cooled by a fan rather than an air conditioner.

3.4 Results of Energy Audit

- (1) Historical development of EGCO TOWER's power consumption

Figure IV-3-6 illustrates the historical development of EGCO TOWER's annual power consumption. In 2000 when the first audit was carried out, the power consumption was reduced in comparison with the previous year. The power consumption has been further reduced.

Figure IV-3-6 Historical Development of Annual Power Consumption

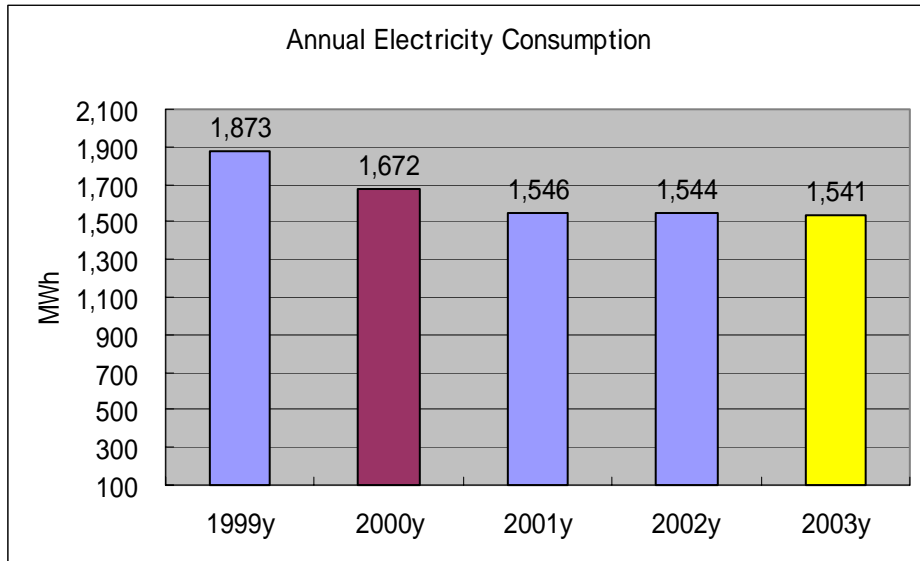

(2) Monthly power consumption

Figure IV-3-7 illustrates the historical development of monthly power consumption from December 1998 to March 1999. Generally speaking, the power consumption is reduced in every month.

Figure IV-3-7 Historical Development of Monthly Power Consumption

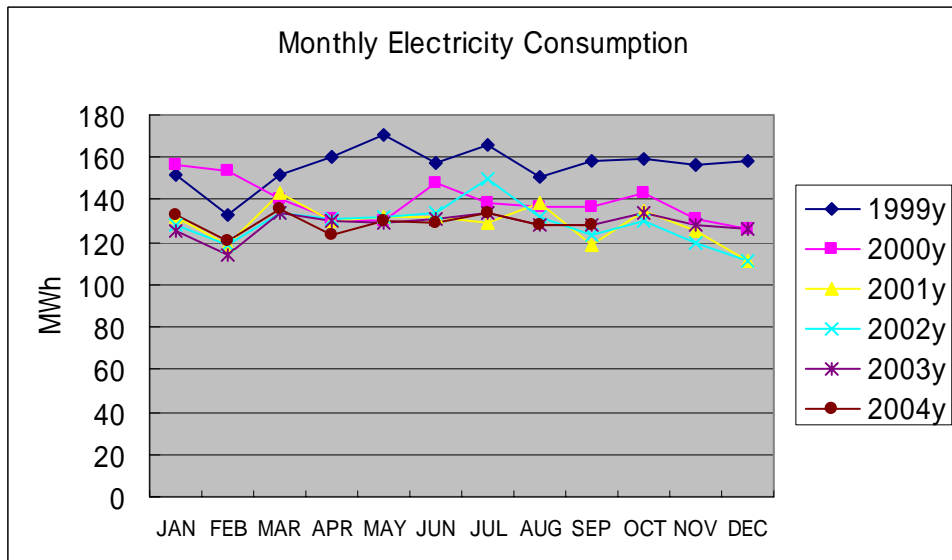

(3) Evaluations of EGCO TOWER's energy use efficiency

The energy use efficiency index (EFF index) is annual power consumption divided by an actually used area of 15,709 m². Thailand's code tells that the EFF index is

150 kWh/yr/m². EGCO TOWER's EFF index is 106 in 2000, and 98 in 2003, being very good.

Figure IV-3-8 Historical Development of the EFF Index

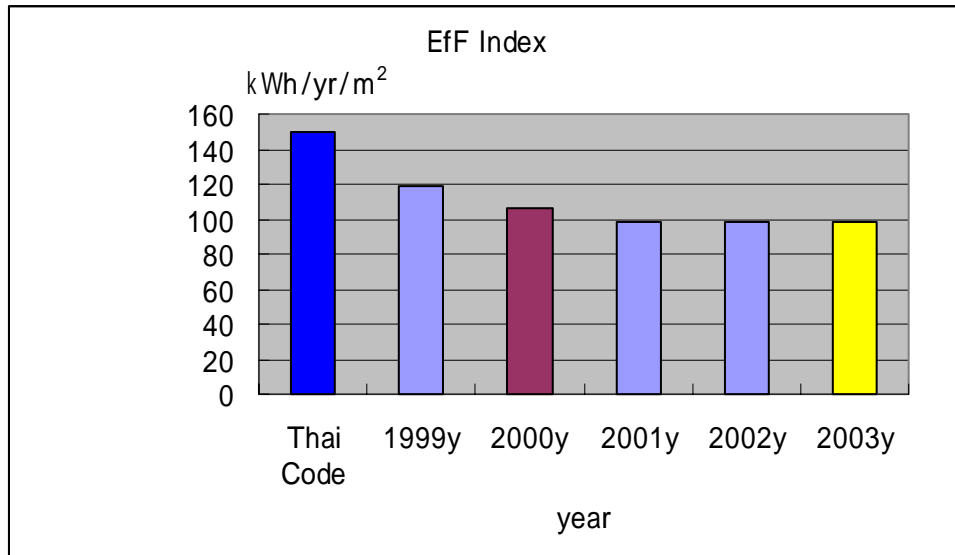

(4) Other energy conservation activities

The EGCO Tower building itself supports high energy conservation performance. The staff members of this firm are also engaged in enlightenment activities using adhesive labels and corporate E-mail messages in order to encourage energy conservation. (See Figures IV-3-8 and IV-3-9.)

Those activities consist of extinction of unnecessary lamps, and restrictions of elevator use when he/she goes to the adjacent upper story.

Figure IV-3-8 Enlightenment Using Adhesive Labels



Figure IV-3-9 Enlightenment Using E-mail messages

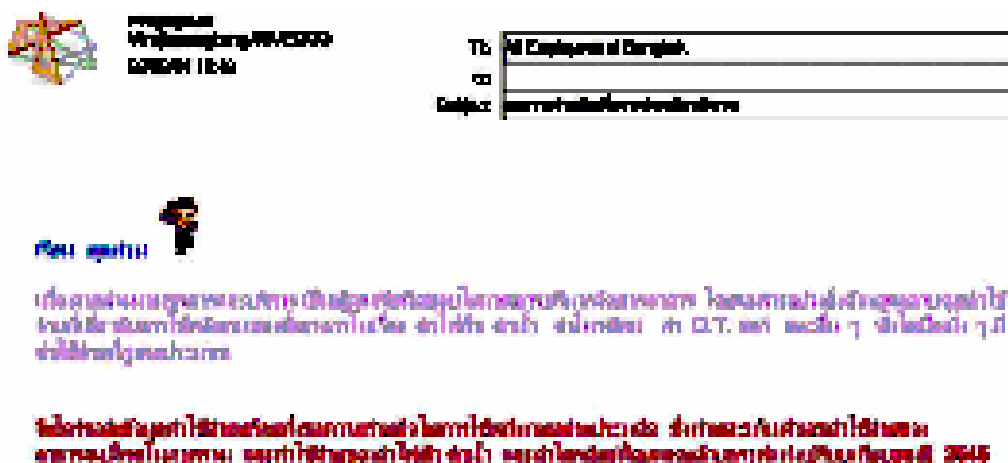

3.5 Problems and Measures for the Promotion of Energy Conservation

(1) Problems in the promotion of energy conservation

EGCO Tower features high energy conservation efficiency, and has deployed excellent energy conservation activities. We can understand the fact that they got the ASEAN best-practice building award. An interviewee, Ms. Prapaporn Virojsaengtong (Vice President – Administration % Services), was also interviewed during the audit in 2000. We suppose that she has been involved actively in energy conservation activities. Energy conservation activities that make use of IT

technologies including E-mail message delivery to all staff members can be rarely found in Japan.

We could find few problems in this building, which is well equipped and has embarked positively on energy conservation activities.

(2) Measures for the promotion of energy conservation

A new management firm has been employed for energy management. The electricity and machine rooms are cleaned and arranged well, with no failed equipment left. The new firm, Jones Lang LaSalle, also seems to be excellent management firm like the previous one.

In the ASEAN buildings including the ones in Thailand, We have often been bothered by a very insufficient measured data. The data which we could access are only the data of total electric power and water usages relating to payment. We have found difficulties with data that are usable to check equipment for efficient operation, and to understand and analyze temporal and systematic energy application to machines. BAS data is not well collected and, therefore, cannot be utilized for the energy application analysis.

Equipment significantly varies in its efficiency depending on its operation mode. This building should be advised of that the data measurement and analyses are important for the energy conservation.

4. About the Result of the Workshop

4.1 Outline

Forty-five people participated in the workshop. About the building-related activities, Thailand gave three presentations and other ASEAN countries also gave three presentations. EGCO Tower gave a presentation on the results of the energy conservation activities. Our experts carried out a follow-up survey for the activities and made the presentation including the results of the follow-up survey. The presentation was very good. There were many questions and discussions in the workshop, allowing the people working in the field of buildings to exchange their opinions and information. The workshop fulfilled its objects successfully.

In the workshop, the participants from Thailand gave presentations in Thai since it was easier for the Thai people who are majority of the participants. We and the people from other ASEAN countries used English to make presentations. The DEDE people occasionally summarized the presentations and discussions in English. However, this method needs some modification since the participants from other ASEAN countries or us could not understand very well.

4.2 Discussion on the Survey Results (Obstacles in Performing and Disseminating Energy Conservation Measures and Countermeasures)

The results of the surveys were reported to the people of EGCO Tower in a separate occasion. The details are not discussed here since they are described elsewhere in this report.

4.3 Policy on Creating the Technical Directory

We explained the basic idea of the Technical Directory and some suggested items to be presented in the Technical Directory at the workshop and received an agreement for their preparation from the participants. The features are as follows:

- Include the technologies that are suitable for Southeast Asia and those that have been recommended by Japanese experts or those actually used in Japan.
- Include successful examples of the above.
- Prepare the basic format that can be easily expanded or changed in the future based on the above.

Our suggestions were agreed upon. We found that DEDE had lots of information including the successful examples.

We discussed and checked the work to be done in Thailand. We asked Thai people to provide the data and information (buildings and industries), which owned by DEDE, according to the sample formats which ECCJ was going to provide. The data and information were written in Thai which is a problem for us. However, we asked Thailand

to prepare the appropriate data. It is highly possible that these data and information can be effectively used in ASEAN countries. We plan to investigate the contents of those data and information in detail.

Workshop Program in Thailand

08.00 – 08.30	Registration
08.30 – 08.35	Opening Statement Dr. Weerawat Chantanakome Executive Director, ASEAN Centre for Energy
08.35 – 08.40	Opening Statement Mr. Yoshida Kazuhiko, General Manager, ECCJ
08.40 – 08.45	Keynote Address & Welcome Remarks Ms. Pranee Rintaravitoon Deputy Director General, DEDE
08.45 – 09.00	Coffee Break & Photo session
Session I :	Policies and Programs on Energy Conservation
09.00 – 09.20	Energy Conservation Policy and Programs of Thailand Mr. Pravit Teetakaew, Executive Director, DEDE
09.20 – 09.40	Japan’s Energy Conservation Programs Mr. Yoshida Kazuhiko Energy Conservation Centre, Japan
09.40 – 10.00	Question and Answer
Session II :	Energy Conservation Best Practices for Buildings in Thailand
10.00 – 10.30	Experience and Application of Energy Conservation in EGCO Hotel
10.30 – 11.00	Experience and Application of Energy Conservation in Shinawatra University
11.00 – 11.30	Experience and Application of Energy Conservation in Mike Shopping Mall
11.30 – 12.00	Question and Answer
12.00 – 13.00	Lunch Break
Session III :	Energy Conservation Best Practices for Buildings in ASEAN Countries
13.00 – 13.30	UTM Building of Malaysia Ms. Azah Ahmad, Ptm, Malaysia
13.30 – 14.00	Alexandra Hospital Building of Singapore Mr. Stewart Tai
14.00 – 14.30	Indonesian Buildings and Air Conditioning Unit Equipped with Heat Pipe for Tropical Building Mr. John Budi
14.30 – 15.00	Question and Answer
15.30 – 16.00	Coffee Break
Session IV :	The Way Forward
16.00 – 16.20	Development of Technical Directory by ECCJ
16.20 – 16.35	Development of Local Database / Benchmark / Guideline by ECCJ
16.35 – 17.00	Closing Statement

4.4 Discussion for Establishing the Database, Benchmarks, and Guidelines in Thailand

In the workshop, we explained the basic idea including how the system worked. We also asked the DEDE people about the activities performed by Thailand on a separate occasion. The results are as follows:

(1) Energy conservation system in Thailand

The energy conservation in Thailand is regulated by Energy Conservation Promotion Act B.E. 2535 which was established in 1992 and enforced in 1995. The details about buildings are described in Royal Decree on Designated Buildings B.E. 2538 and Ministerial Regulation B.E. 2538.

The main points are as follows:

- The target buildings are those with 1,000 kW or 1,175 kVA or greater transformer capacity.
- The monthly energy data on the designated buildings must be checked every six months by the energy manager (Person Responsible for Energy (PRE)) and submitted.
- There are about 1,800 applicable buildings (reference: the number of factories to have similar responsibilities is about 2,600).

(2) About the database, benchmarks, and guidelines

DEDE collects the energy data about each of the designated buildings based on the above regulation. Then DEDE input the data into their database and creates benchmarks.

Feedback reports are sent to the designated buildings. The outline of a feedback report is as follows:

- There are six categories for buildings in terms of how they are used (hotel, hospital, department store, office, school, and other types)
- The Specific Energy Consumption (SEC) is used as the evaluation index of energy consumption.

SEC Total (total energy consumption): MJ/m²

SEC e (electric energy): kWh/m² (the energy is converted to MJ considering 1 kWh = 3.6 MJ)

SEC f (fuel): MJ/m²

- The data is analyzed and the following three index values are then reported.

Average: Average in each category of data

Target: Top 25%

Benchmark: Top level value

- The reports consist of the following items to be submitted by the designated

buildings:

- 1) Outline of the building
 - 2) Monthly energy consumption and monthly fuel consumption for generators
 - 3) Working ratio of the building
 - 4) Energy conservation activities
- Signature of PRE

The system of feedback reporting started in 2002.

V. The Philippines

1. Activity Overview

In the Philippines, we carried out a follow-up survey at Tower One & Exchange Plaza, and a simple energy audit at DPC Place. These buildings are used for business. We also held a workshop.

The following gives a list of participants and task records.

Participants from the International Engineering Department of the Energy Conservation Center, Japan (ECCJ)

- Kazuhiko Yoshida (General Manager)
- Akira Kobayashi (Technical Expert)
- Yohichi Kita (Technical Expert)

Task records

Date		Description
November 7	Sunday	Left Bangkok, and arrived at Manila.
November 8	Monday	Carried out a follow-up survey at Tower One & Exchange Plaza.
November 9	Tuesday	Carried out a simple survey at DPC Place.
November 10	Wednesday	Arranged the results of the audit.
		Reported the results of the follow-up survey at Tower One & Exchange Plaza.
November 11	Thursday	Reported the results of the simple survey at DPC Place.
		Made discussions with relevant DOE personnel (to generate databases, benchmarks and guidelines, and create a technical directory).
November 12	Friday	Held a workshop.
November 13	Saturday	Left Manila for Japan.

We carried out the follow-up survey at Tower One & Exchange Plaza, a business building that had carried out the energy audit in March 2002. The follow-up survey consists of:

- pre-sending a questionnaire;
- letting building staff respond with the achievements of taking its own measures and measures for more effective energy conservation particularly recommended by Japanese experts;
- acquiring data on latest energy application; and
- investigating into and checking the data at the site.

The energy audit used the conventional approach consisting of:

- pre-sending a questionnaire;
- letting building staff collect data and information necessary for the energy audit; and
- measuring and checking the data at the site during the actual investigation based on the OJT scheme to secure technological migration.

The workshop was attended by 88 persons including members of universities and building

related organizations, civil building managers, and ESCO's staff members. The number of attendants recorded the highest value among the workshops of this year. The workshop ended successfully after very active discussions.

2. Recent Trends of Energy Conservation and Building Management in the Philippines

2.1 Trends of Energy Conservation in the Philippines

The following gives recent trends presented by the ACE.

Energy Supply Mix (2003)

The Philippines is heavily dependent on imported fuel as energy source. Local energy sources are: (a) Natural Gas; (b) Coal; (c) Geothermal; (d) Hydro; (e) Biomass; (f) New & Renewable Energy of Solar and Wind; (g) Fuel Oil and (h) Coal. Table below shows the percent share of energy source demand.

Energy Supply Mix (2003) MMBFOE

	Local Energy Source		Imported Energy Source	
Fuel Oil & Oil Products	4.71	1.7%	116.66	42%
Natural Gas	17.06	6.15%		
Coal	6.5	2.34%	21.83	7.89%
Geothermal	16.94	6.1%		
Hydro	13.57	4.9%		
Biomass, NRE	80.29	28.92%		
TOTAL	139.07	50.11%	138.49	49.89%

Energy Program

The energy program of the country is directed towards one of the five point agenda for reform by the present government. These are (1) economic growth and job creation; (2) anti corruption through good government; (3) energy independence; (4) social justice; and (5) education and youth opportunity.

To be able to reduce dependence on imported fuel, the government shall pursue the following:

- increase indigenous oil and gas reserves;
- aggressively develop renewable energy potential such as biomass, solar, wind and ocean resources;
- increase use of alternative fuels
- form strategic alliance with other countries
- strengthen and enhance energy efficiency and conservation program

Transport Sector

The transport sector is the most badly affected by increase in international fuel price. This is due to the reason that the oil industry is deregulated and can adjust fuel prices accordingly. Diesel Fuel is used mostly by the public transport sector and the oil companies give discount for diesel fuel purchase of public transport vehicles.

To be able to lessen effect of world price increase of fuel oil to public transport, the government is promoting the use of natural gas fuel for public buses. The NGV bus shall serve the main bus route of Metro Manila. To date, two (2) NGV buses are used for demonstration to bus companies and the public commuters to accept this new type of bus using alternative fuel. A mother station for Compressed Natural Gas Filling Station was recently inaugurated. Sister stations for CNG Filling Station will soon be put up in the Manila Metropolis.

Another program to ease effect of fuel price increase is the use of bio-fuel. The government is promoting the use of coco-methyl ester or CME as blend for diesel fuel. Currently, a 1% CME blended diesel fuel is used by government vehicles and encourage the motoring public the use of this bio-fuel.

Current gasoline and diesel fuel prices are as follows:

Gasoline – US\$ 0.5454 per liter

Diesel – US\$ 0.4545 per liter

Diesel with discount – US\$ 0.4364 per liter

Electric Power

The country's peak demand grew from 7,721 MW in 2002 to 8,204 MW by the end of 2003. Total installed electric generating capacity is at 15,124 MW as of 2003.

Coal fired power plants remained the dominant type of power plant accounting for 26.2%. Oil based power plants comprised 23.8% of capacity mix.

Consequently, Hydro power plants became the highest indigenous resource with a share of 18.9% closely followed by Natural Gas power plants at 18.3%. Geothermal power plant capacity is at 12.8% of the power capacity mix.

Electric power utility follows a complicated billing scheme known as unbundled rates. Aside from the usual power demand and energy consumption, several other factors are considered in the electric bill, i.e. primary voltage level, load factor, system loss, subsidy, etc. Also, electricity price is different among the different places of the country which are mostly island grids. However, a dominant utility company in the national capital region covers most of the Luzon area and their electricity price can be used as the reference rate. Small residential electricity price is subsidized. The subsidizing commercial and industrial companies give different subsidies according to the size of the factory.

Electricity Rates

Subsidized residential rate - US\$ 0.0636 per kWh

Residential - US\$ 0.127 per kWh

Commercial - US\$ 0.118 per kWh

Industrial (High Load Factor) - US\$ 0.09 per kWh

Note: Preceding electricity rates are typical for each sector and it considered the overall cost including discounts and taxes.

Industrial/Commercial Sector

Energy used in the industrial sector is mostly electricity and Bunker C oil. Some companies use Diesel fuel especially in commercial buildings like hotels and small and medium enterprises. Furthermore, other commercial establishments use Liquefied Petroleum Gas (LPG) for heat energy requirement.

The sugar mills generate their own electricity requirement. They also use their own agricultural waste as fuel. The coconut industry also uses agri-waste fuel but not for electricity generation rather it is used for heat energy requirement. A few large industrial companies of cement, paper, glass and textile are self generating electricity using diesel engine generating sets.

Residential

Energy in the residential sector are electricity, LPG and some kerosene. In agricultural areas, however, they use biomass fuel, like wood and agri-waste fuel. In areas outside main electricity grids, photovoltaic systems were installed. In other areas, lamp oil is used for evening lighting and dry cell batteries for electric power.

Future Requirement

Additional generating capacity is required for the coming years. By 2008, about 300 MW additional capacity is required and there are about 393 MW of power generation projects using either renewable or conventional oil already committed. However, further electricity demand increase is expected in 2010 and no committed power projects were developed yet.

2.2 Trends of Building Management in the Philippines

The following gives recent trends presented by the ACE.

3. Follow-up Audit on Tower One & Exchange Plaza

3.1 Tower One & Exchange Plaza Overview

- (1) Name of the building: Tower One & Exchange Plaza



- (2) Application: Business building
- (3) Four stories under and 35 stories above the ground
Total floor area: 105,685 m²
Parking area: 37,525 m²
- (4) Constructed in: 1995
- (5) Air conditioning equipment
- a. Freezer
 - Chillers: 600 × 3 units, 400 × 1 unit
 - Cooled water pumps: 55 kW × 3 units, 37.5 kW × 1 unit
 - Cooling water pumps: 55 kW × 3 units, 45 kW × 1 unit
 - b. Air-conditioning system
 - Lower and medium stories (4th to 23rd stories): Fan coil unit and external controller (49,040 m³/h × 2 units), Heat exchanger (80,080 m³/h)
 - Higher stories (24th to 35th stories): VAV system, air conditioners (151,870 m³/h × 2 units), Heat exchanger (20,440 m³/h)

(6) Electric equipment

- a. Substation: Received voltage: 34.5 kV
Four substations (2,500 kVA), Automatic power factor adjuster
Five emergency generators (1,250 kW)
- b. Lights: T8 lamps (3 × 17 W) for the business room zone
- c. Elevators
For lower stories: 40 kW × 3 units
For medium stories: 45 kW × 4 units
For higher stories: 30 kW × 3 units
For high-speed operation: 56 kW × 2 units
For services: 49 kW × 1 unit
For the stories under the ground: 39 kW × 3 units

(7) Energy management system

The BEMS (Building Energy Management System) is installed to control mainly air conditioning, illumination and ventilation.

3.2 Outlined Results of the Audit in 2002

- (1) The audit was carried out on March 14 and 15, 2002.
- (2) Audited by: Energy Conservation Center, Japan
Yuh Isome (Technical expert) and Akira Kobayashi (Technical expert)
- (3) Outlined results of the audit
 - 1) High-level energy management by APMC
The facilities are managed by APMC (Ayala Property Management Corporation). This corporation provides high management capability, performing excellent energy management. The following gives concrete data on management and improvement.
 - The temperature of the cooled water outlet in the freezer is set properly in conformity to seasonal requirements.
 - The lighting in the common zone is controlled based on the time.
 - The following measures for improvement have already been taken.
 - The inlet vanes for two air conditioners are controlled by inverters.
 - The fan is controlled by an inverter.
 - Incandescent lamps rated at 40 W in the common zones in the first to 23rd stories are changed to compact fluorescent lamps rated at 8 W.
 - Light adjusters are installed in the 25th to 34th stories.
 - Fluorescent lamps rated at 40W2 in the second to forth levels under the ground are replaced by fluorescent lamps rated at 40W1 including

reflecting plates.

- The period of chiller operation is improved.
- The period of operation of ventilating fans in the parking area is improved.
- The period of illumination in the common and parking areas is improved.
- Water taps are provided with water savers.

The following gives the measures that are taken currently and that will be taken in the near future.

- a. To use inverters to control the chiller's cooled water pump and the cooling water pump (During construction. This will lead to a reduction of 26,900 kWh/h)
 - b. To use balls to clean the chiller's condensation pipe (During construction. This will lead to a reduction of 11 percent in chiller power.)
 - c. To change guide lamps to high-brightness guide lamps (Power will be decreased from 10 W to 1.5 W. This will result in a reduction of 1,800 kW/m.)
- 2) Two proposed items for improvement

As described above, the management is performed properly. We have, however, proposed the following two items according to a site patrol investigation.

To close the direct intake damper for AHU-1 and 2 to reduce energy consumption

Air conditioners AHU-1 and AHU-2 that supply external air to lower and medium stories of the fourth to 23rd should introduce all external air via a heat exchanger as per the normal procedure. With the site damper opened, however, external air is introduced without flowing through a heat exchanger. This prevents a heat exchanger from being utilized suitably for the energy conservation. We propose that the direct air intake damper should be closed.

To increase the set temperature in the room by 2 °F from 75 °F (23.9°C) to 77 °F (25.0°C)

This increase will make it possible to reduce cooling power by about 10 percent.

3.3 Follow-up Survey on the Previous Proposal

The following gives the results of the follow-up survey for the items proposed previously in 2002.

- (1) To close the direct intake damper for AHU-1 and 2 to reduce energy consumption

External air was introduced directly without flowing through a heat exchanger because the heat exchanger was failed (the motor is out of order and the V belt has defects) and did not work well. It was reported that they were preparing for the repair work at that time and the work would be completed within that month.

- (2) To increase the set temperature in the room by 2 °F from 75 °F (23.9°C) to 77 °F (25.0°C)

The building's staff reported that an attempt for this increase had been canceled owing to a complaint from a tenant.

3.4 Results of Energy Audit

- (1) Trend of energy consumption

Electric power and LPG are used as energy for the building. LPG is applied to cooking, and occupies merely 0.5 percent of total energy. Our investigation focused on electric power consumption.

- 1) The trend of monthly power consumption for three years

The chart below illustrates the trend of monthly power consumption for the past three years and for January to September in 2004. In December of every year, electric power consumption is reduced in comparison with the other months possibly because of low air temperature and holidays including Christmas in those months. This chart indicates that energy consumption is reduced from 2001 to 2003. The next chart compares annual total power consumption.

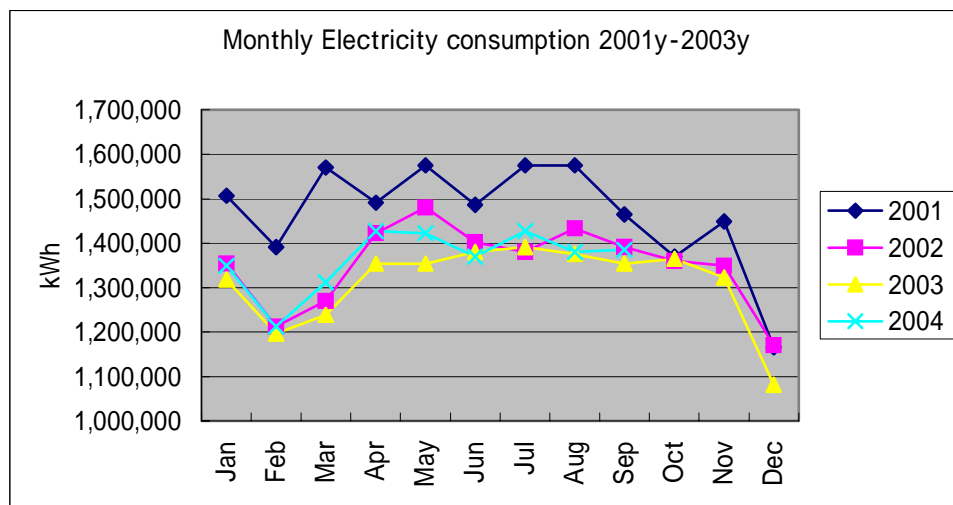

- 2) Electric power consumption and office occupancy rate for the three years
- The bar chart below compares annual power consumption against 2001 (100 percent). Electric power consumption is reduced by 8 percent in 2002, and by 11 percent in 2003, showing a steady reduction over the years. The broken-line chart below illustrates the rate of building occupation for the three years. In 2003, this rate is increased in comparison with 2002, while electric power consumption is reduced. This tells that efforts for energy conservation have produced fruits.

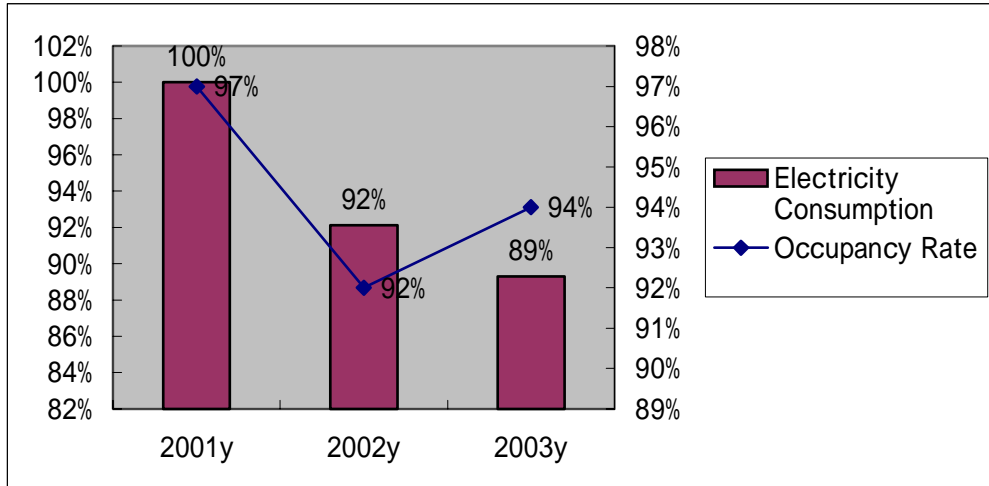

- 3) Monthly electric power conservation in the common and tenant area
- The chart below shows monthly electric power consumption in the tenant and common area in 2003. The power consumption in tenant area is rarely changed monthly, while the power consumption in common area including heat source is changed monthly owing to effects of atmospheric temperature.

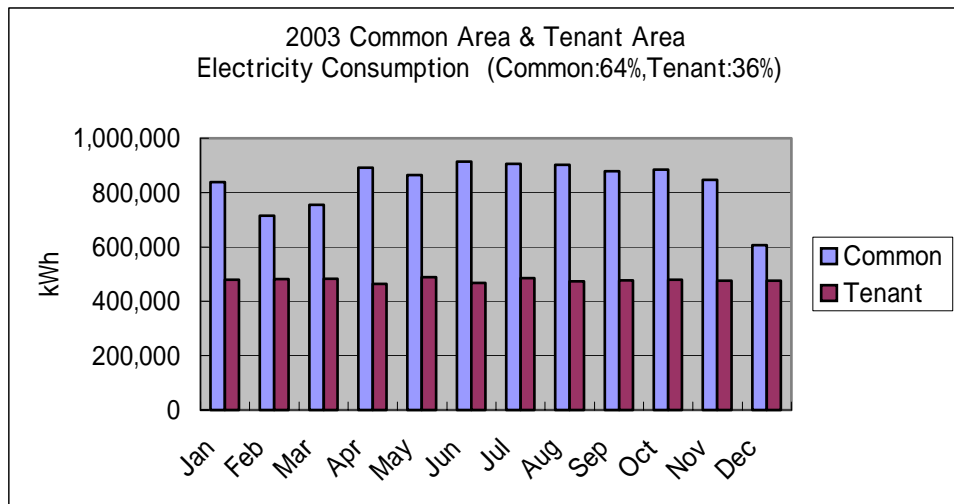

4) Energy consumption ratio by use

The pie chart below illustrates the Energy consumption ratio by use identified during the investigation in 2002. This is nearly the same as the ones of Japanese office buildings.

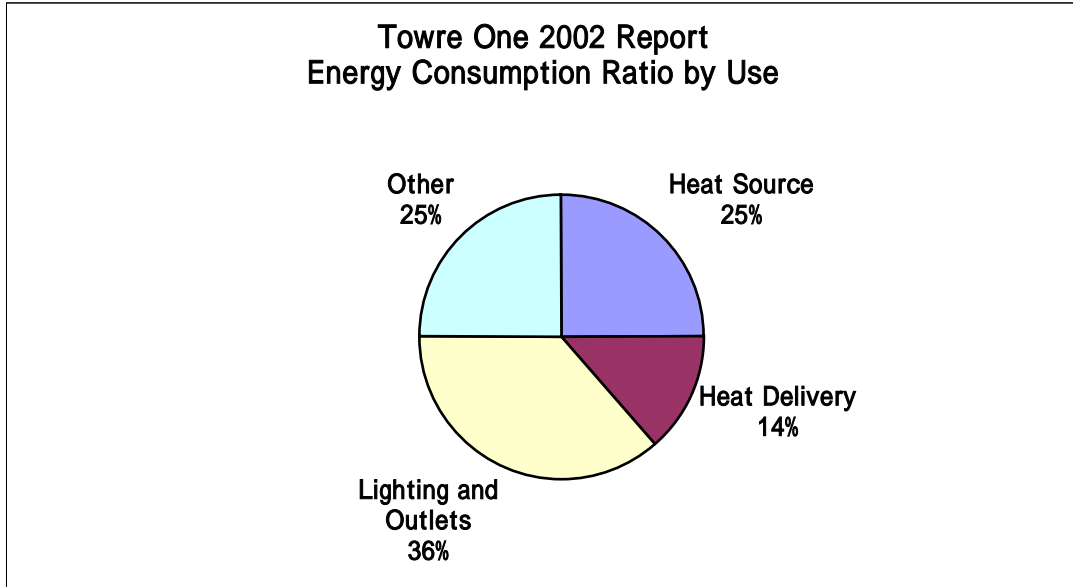

5) Monthly water usage

The chart below shows monthly water usage for the past three years. The values for August to October in 2001 are apparently abnormal in comparison with the other years. Looking into monthly values in 2002 tells that mean values are not significantly changed monthly. November in 2003 marked the peak value possibly because of a particular event.

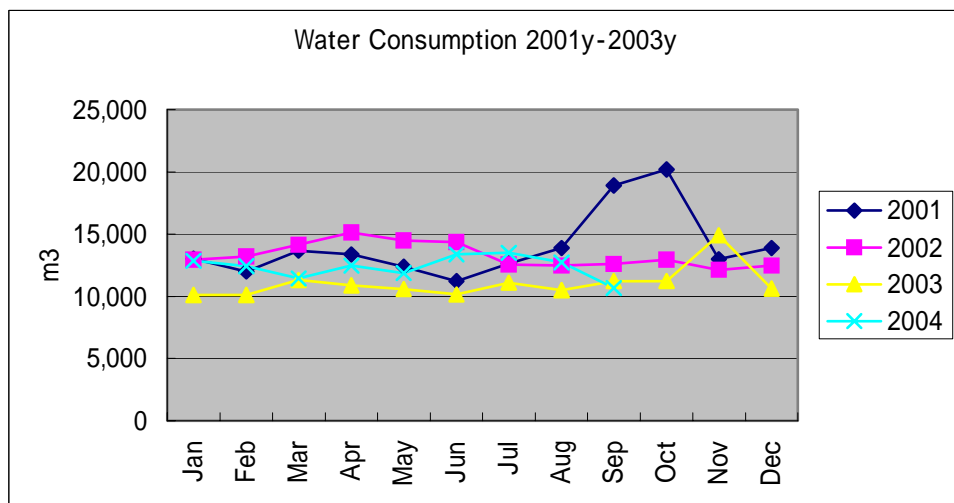

6) Changes in water usage for the three years

The chart below compares annual water usage for the three years. The value in 2002 is 95 percent, and that in 2003 is 79 percent against 2001 (100 percent). This reduction apparently reflects installed tap water savers, and utilized air-conditioner drain water.

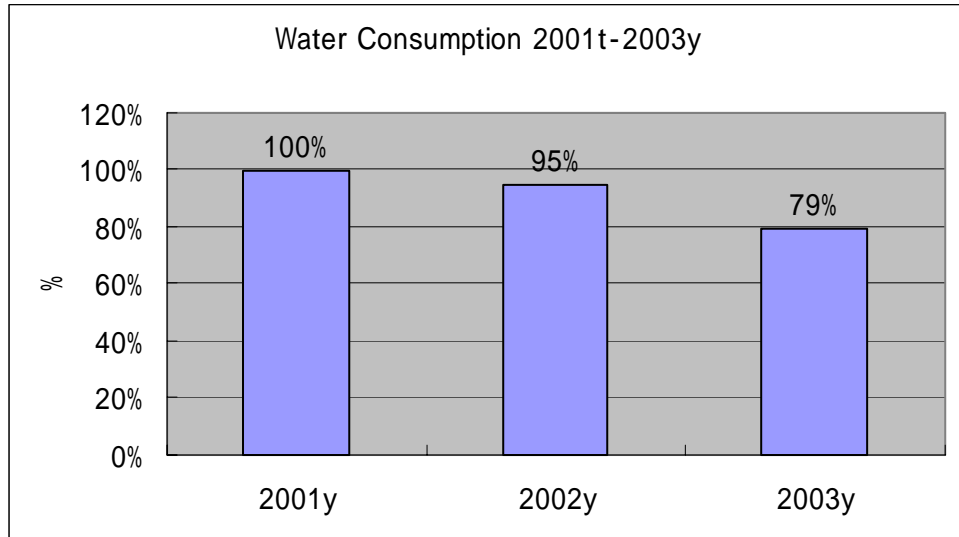

(2) Evaluations of energy consumption

1) Differences in temperature between the Philippines and Tokyo

To evaluate energy consumption by this building, we refer to Japanese data because we have no comparable data of the Philippines. To understand conditions of ambient temperature that significantly affect air-conditioning energy consumption, we have got data on monthly average temperature in the Philippines (Manila) and Tokyo.

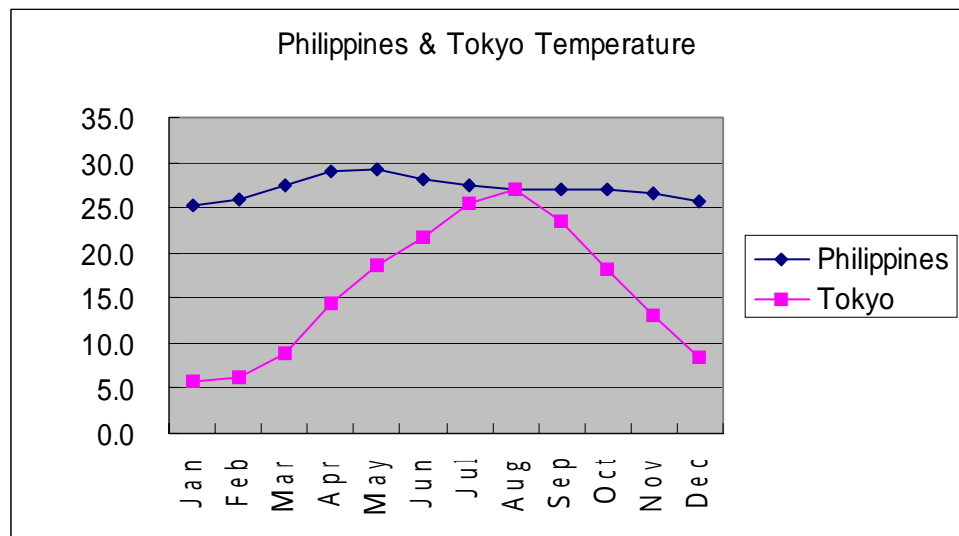

2) Energy efficiency by Japanese building applications

Data offered by Energy Conservation Center provides the following energy efficiency index for Japanese building applications. The value for a business building is 2,180 MJ/m².

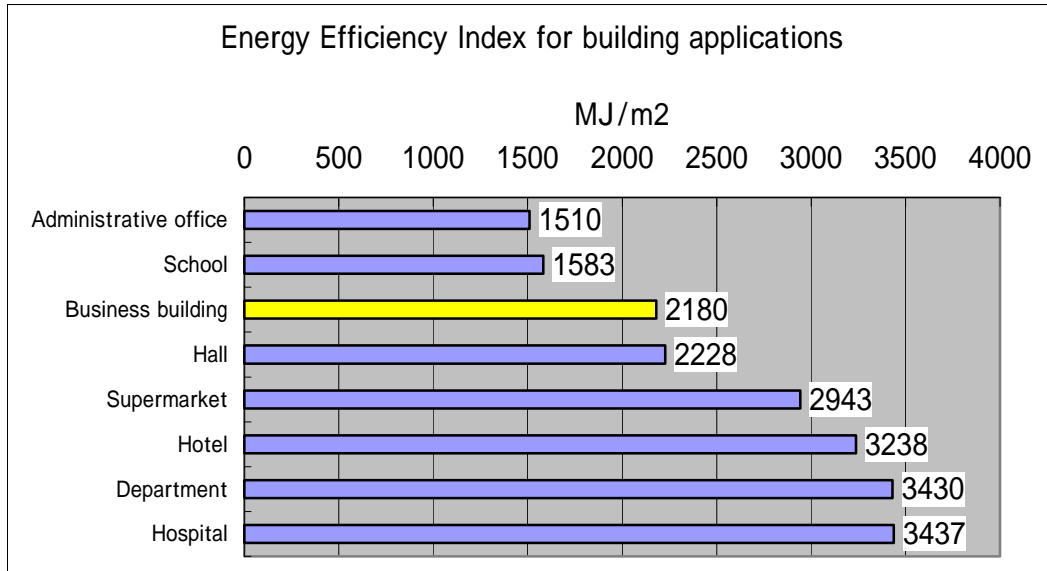

(3) Comparison of Tower One with a Japanese business building

Energy consumption by Tower One is evaluated using the Japanese average value presented by the Energy Conservation Center.

To convert Japanese MJ into corresponding kWh, we use 1 kWh = 9.8 MJ taking account of Japanese power generation efficiency, though the physical formula indicates 1 kWh = 3.6 MJ.

For energy conservation, compared with the Japanese value, in case that a total floor area includes parking area, the energy efficiency index of this building is 66.9 percent of the Japanese one. In case that the floor area excludes a parking area, it is 103.8 percent. In the consideration of the annual high temperature and the fact that Japanese data also covers the parking area, it can be said that this building is operated and managed efficiently for the energy conservation.

Electric power consumed by Tower One in 2003	15,734,250	kWh
Total floor area	105685	m2
Total floor area (excluding the parking area)	68160	m2
Tower One (Total)	148.9	kWh/m2
Tower One (excluding the parking area)	230.8	kWh/m2
Japanese business building	2180	MJ/m2
Coefficient used to convert MJ into corresponding kWh	1/9.8	
Japanese business building	222.4	kWh/m2
/	66.9%	
/	103.8%	

The chart below illustrates the consumption of energy per unit area.

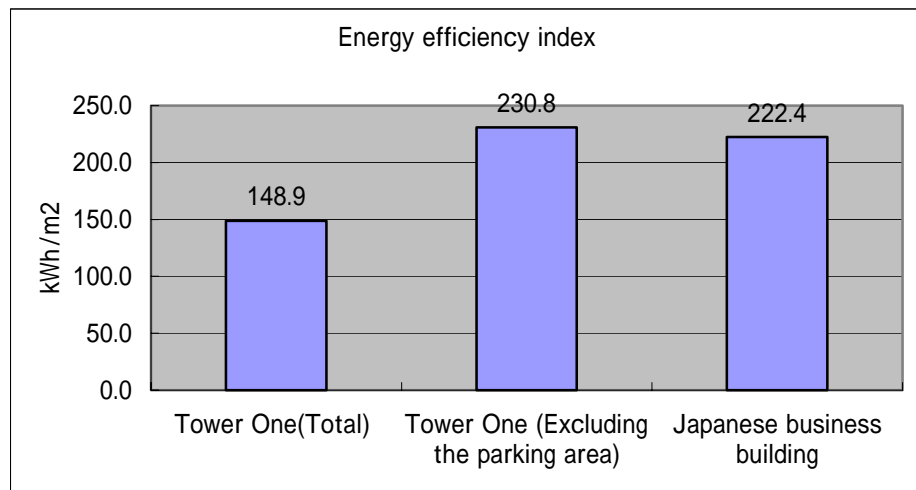

(4) Proposals for improvement

This building is characterized by excellent energy management and positive activities for energy conservation, producing high achievements as shown above. After the site patrol and data analyses, we proposed the following three points for future improvement.

1) Data analyses utilizing the BAS

This building is provided with the BAS (Building Automation System) and well controls air-conditioning. It has not, however, implemented active energy management for electricity. Measuring power consumption of every air conditioner by each feeder and analyzing the measured data would contribute to further energy conservation.

2) Changes in cooled water temperature settings

The chart below shows cooled water outlet temperatures of the three chillers referred from their operation records on October 28, 2004. (Chillers Nos. 2, 3

and 4 are run.) The problem consists in the facts that the average cooled water outlet temperature is very low (43.3 °F (6.3°C)) and that the average temperature difference between forward and return flowing is also very low (6.0 °F (3.3°C)). (See the chart below.)

In the season such as October when light loads are applied, setting the cooled water temperature to a higher value would produce no significant effects on air conditioning. This setting would lead to more efficient chiller running, with energy conservation. We recommend that the cooled water temperature be set to a higher value in the months of light loads season.

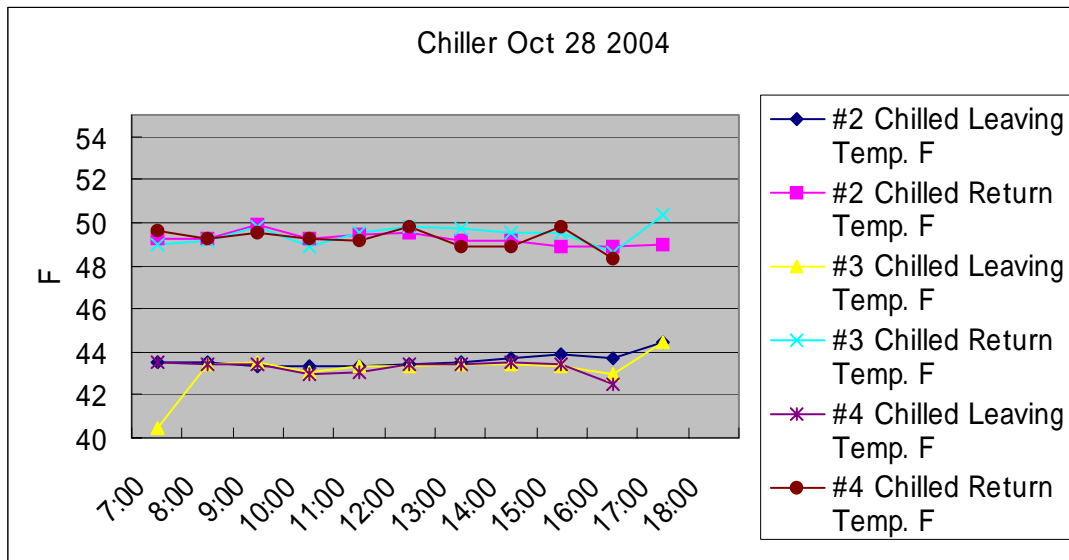

Electric power consumed in 2003	15,734,250	kWh
Chiller percentage	0.25	
Electric power consumed by the chiller	3,933,563	kWh
Power percentage for nine months	0.6	
Rate of reduction effects	7	%
Reduction	165,210	kWh
Share in total electric power	1.1%	

Oct 28 2004

	F		C	
Chilled Leaving Temp Ave	43.3	6.0	6.3	3.3
Chilled Return Temp Ave	49.3		9.6	

Recommend

	F		C	
Chilled Leaving Temp Ave	47.3	9.0	8.5	5.0
Chilled Return Temp Ave	56.3		13.5	

Leaving Temp 43.3F (6.3 °C) →47.3F (8.5 °C)

$\Delta T=4F(2.2C)$

Effect 7 %

The light load season is assumed the nine months (excluding three months from March to May) when the air temperature is relatively low. If we assume that 7 percent is the improvement of efficiency achieved by changing cooled water temperature settings from 43.3 °F (6.3°C) to 47.3 °F (8.5°C), the above table calculates a power consumption reduction. The reduction rate in the total power consumption is 1.1 percent.

3) Checking of the number of running chillers

The chart below gives data on the opened slide valve of the chiller identified referred from the chiller operation records on October 28, 2004. (The chilling capability of each of chiller, Nos. 2 and 3 is 600 RT, while the one of chiller No. 4 is 400 RT.)

During start-up, each of chillers 2 and 3 is opened by 85 percent, while chiller 4 by 44 percent. This means that, for nearly three hours from the start of running, full operation of chillers 2 and 3 may cover the entire cooling load without running chiller 4. After ten o'clock, chiller 4 is run by 70 percent, which indicates the three chillers should be operated.

The careful study of the number of running chillers in the stage where air temperature is low will lead to more effective energy usage for the pump, the cooling tower, and other auxiliary equipment.

The current BAS system can determine the optimum number of running chillers by means of thermal calculations. We propose the installation of such a BAS system.

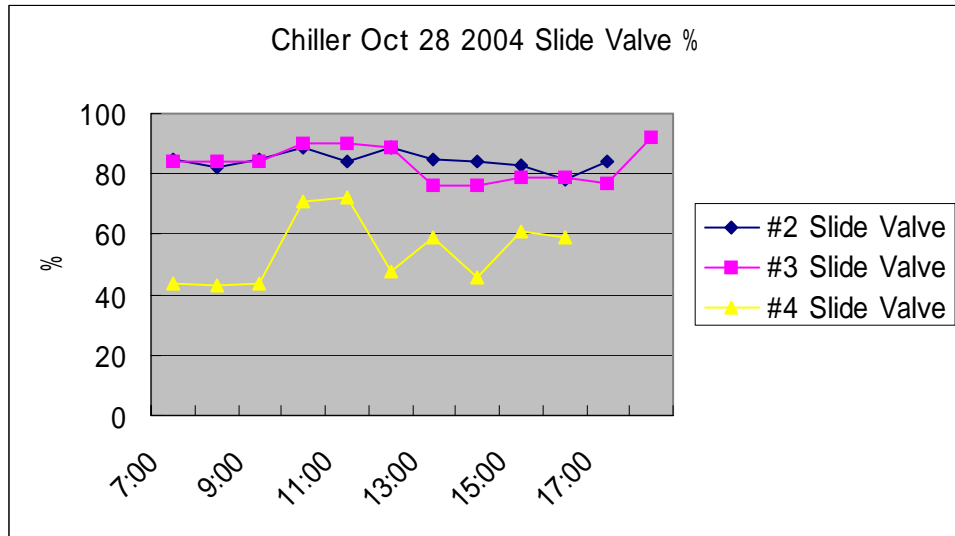

(5) Introduction of useful technologies

- 1) CO2 concentration control to determine suitable quantity of outside air to be brought in

In Japan, the volume of open air to be brought in is controlled based on the CO2 concentration as the index. The Table below describes room environmental standards in a Japanese building. According to these standards, the allowable CO2 concentration in rooms is 1,000 ppm.

Temperature	17 ~ 28
Humidity	40% ~ 70%
Wind velocity	Below 0.5m/s
Suspended solid	Below 0.15mg/m3
CO	Below 10ppm
CO2	Below 1000ppm

In a tenant room in Tower One, we used a simple measuring instrument to measure the values, and showed them how to measure them. This is shown in the photo below. During measuring, we identified a value of 1,000 ppm in the 5F tenant area under the ambient outside concentration of 400 ppm. Although this value is the limit of the environmental standards, this value indicates proper control of the ventilation for energy conservation.



2) Large-temperature-difference air-conditioning system

Some Japanese buildings adopt a large-temperature-difference air-conditioning system for energy conservation.

For example, in case of the large-temperature-difference air-conditioning system, a temperature difference is set to 7 or 10°C although the cooled water temperature difference is normally designed to 5°C. The difference of 7°C would enable a reduction of 29 percent in pump power, while a difference of 10°C would enable a reduction of 50 percent.

As the cooled water temperature difference in this building is very small as shown above, we propose that the volume of leaving cooled water should be reduced in a large-temperature-difference AC system and as the result the cooled water pump power will be decreased.

Since the cooled water pump is provided with an inverter controller (VSD), changing frequency settings allows the leaving water volume to be varied. We should, however, study this carefully since the pump's water head is also reduced.

3.5 Problems with and Measures for the Promotion of Energy Conservation

(1) Problems with the promotion of energy conservation

In the audit in 2002, we proposed that the room temperature be increased by 2 °F from 75°F (23.9°C) to 77 °F (25.0°C). The APMC attempted to follow our proposal, but this attempt was canceled owing to the tenant's complaint. The office building with tenants should put more emphasis on services for the tenants. "The building owner is most concerned over a tenant complaint and try to give their tenants better services in order to make the tenants to continue to stay in the building at a high rent."

For the promotion of energy conservation in tenant office buildings, understanding and cooperation of the tenants is indispensable in ASEAN countries as well as in Japan..

(2) Measures for the promotion of energy conservation

Despite the above barriers of tenants' cooperation, this building has very successfully deployed energy conservation promotion activities. We think that this success has come from their high management and engineering capability as the property management firm.

The APMC has the following plans for further improvement.

- Cooling tower fan speed controller (VSD)

- Accumulated ice heat

- Evaporation cooling

- Roof planting technologies

The APMC is working very actively for energy conservation. The ASEAN countries should learn this attitude.

4. Energy Audit of DPC Place

4.1 Outline of DPC Place

DPC Place is a middle-size office building with tenants mostly of communications and IT companies.

The building was originally built with four floors in 1970s. It underwent a major renovation from 1999 to 2000 to become a 16-story building.

DPC stands for Directories Philippines Corporation which publishes telephone directories in the Philippines.

Cyan Management Co. is an IT company and conducts property management of buildings.

We talked to Mr. Jaime G. Silva (Building and Leasing Manager) of Cyan Management Co. and several others.

(1) Name: DPC Place



Figure V-4-1 Exterior of DPC Place

(2) Use: Office

The building opened from Monday to Saturday.

The cooling tower operated from 7:00 to 18:00. The air conditioners could operate after working hours. The elevators operated 24 hours.

(3) Size: One floor below the ground, 16 floors above the ground. Total floor area: 24,836 m² (including the parking lot).

Area of the parking lot: 6,527 m² (the parking lot occupies part of the second to seventh floors).

- (4) Year of completion of renovation: 2000 (originally opened in 1975)
- (5) Outline of facilities
 - 1) Outline of the Building Automation System (BAS) facilities
All devices were manually run by the building staff. There were sub-meters for measuring the energy used by the tenants. The time when the air conditioners stopped running was recorded.



Figure V-4-2 Watt-Hour Meters

- 2) Outline of electrical systems
 - a. Substation
Main transformer: 34.5 KV/230 V, 60 Hz, 3,000 KVA \times 1 unit
Contract power: About 1,000 KW
 - b. Power station
Emergency generator: MGS-series manufactured by Mitsubishi Heavy Industries \times 1 unit
The emergency generator could supply about 65% of the required electric energy at a power failure.
 - c. Elevators
For carrying people: Variable-speed control \times 4 units
- 3) Outline of air-conditioning systems
Cooling towers: Open type \times 3 units
Water cooled packaged air conditioners: Two units of 10 to 20 tons manufactured by Mitsubishi Heavy Industries/floor



Figure V-4-3 Cooling Tower



Figure V-4-4 Water Cooled Packaged Air Conditioner

4.2 Analysis of Current Status

(1) About the management of facilities

Although there was no Building Automation System (BAS) or the like, the management company (Cyan Management Corporation) conducted detailed management. Since the electric power charge is rather high (about 12 yen/kWh), the awareness for energy conservation was high. With understanding and cooperation from the tenants, DPC Place was eager to achieve energy conservation by conserving electricity for lightings, elevators, and air conditioners depending on the operation hours of the offices.



Figure V-4-5 Two-Lamp Fluorescent Lighting with One Lamp Off

(2) Usage of electric power and water

1) Electric power demand

The following figure shows the monthly electric power demand (maximum power) in 2003. There is no significant change throughout the year.

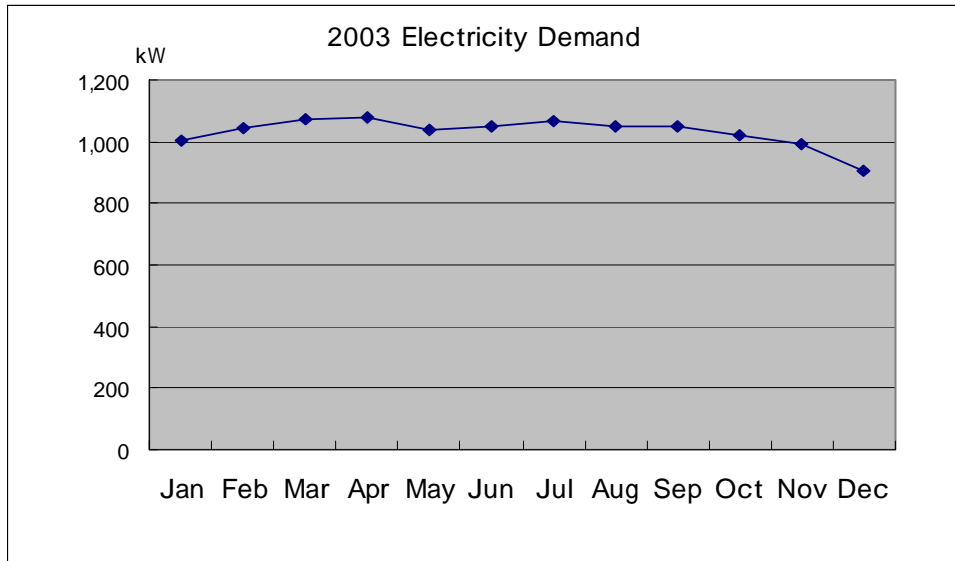

Figure V-4-6 Monthly Electric Power Demand

2) Monthly electric energy consumption

The following figure shows the monthly electric energy consumption in 2003. There is no significant change throughout the year except December where the consumption is a little less.

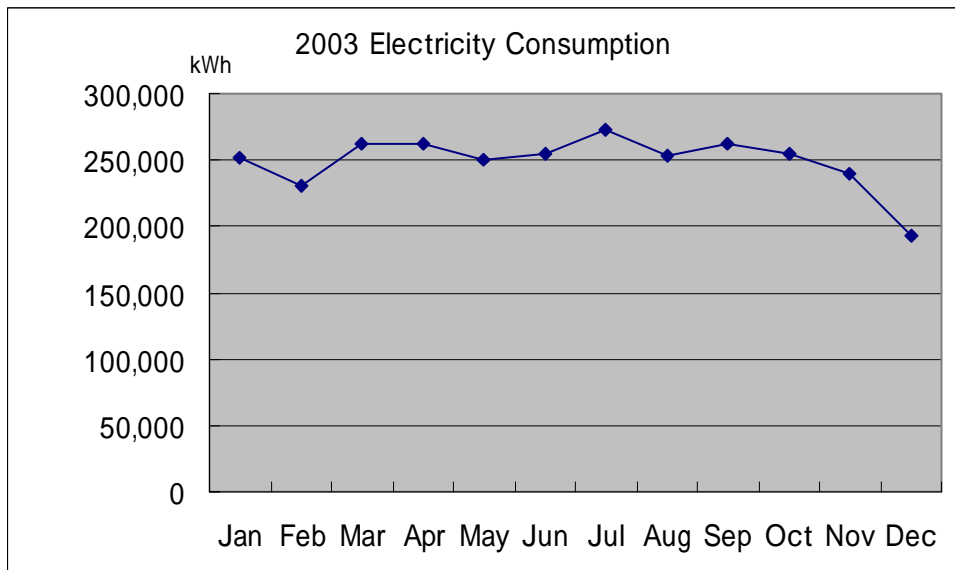

Figure V-4-7 Monthly Electric Energy Consumption

3) Percentage of electric energy consumption by tenants and percentage of electric energy consumption in the common area

The following figure shows the percentage of the electric energy consumption by tenants and the percentage of the electric energy consumption in the common area from April to December in 2003.

In DPC Place, the electric energy consumption by the tenants was very large. This is probably because most of the tenants were IT companies. We heard that DPC Place asked the tenants to stop air conditioners during the lunch break. Still, energy conservation was difficult.

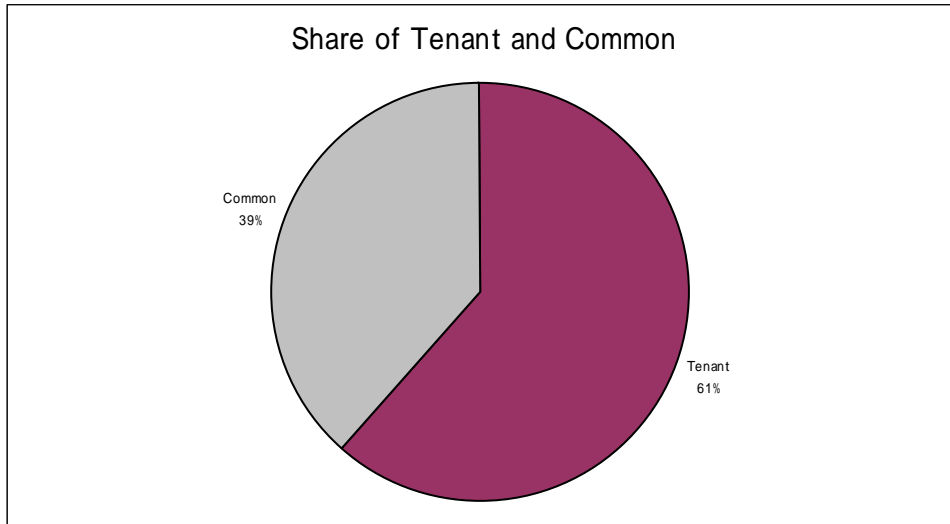

Figure V-4-8 Percentage of Electric Energy Used by Tenants and Common Area

4) Percentage of electric energy consumption by use

When you look at the electric energy consumption by use, the lightings and outlets configure a large part compared to the office buildings in Japan. This is probably because the tenants used lots of lightings for long hours.

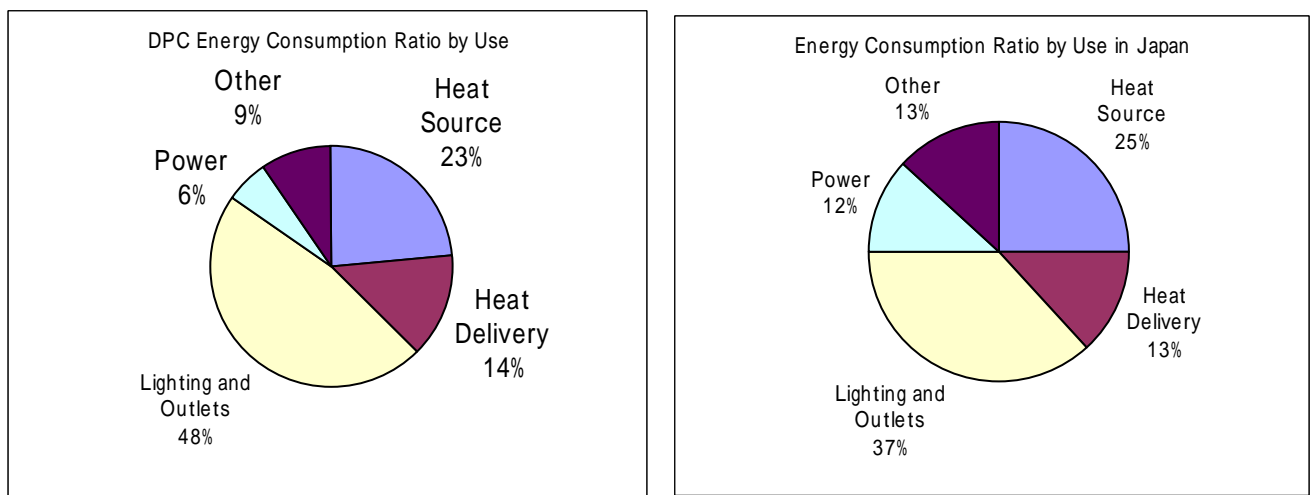

Figure V-4-9 Percentage of Electric Energy Consumption by Use

5) Monthly water consumption

The following figure shows the monthly water consumption in 2003. There is

no significant change throughout the year except December where the consumption is a little less.

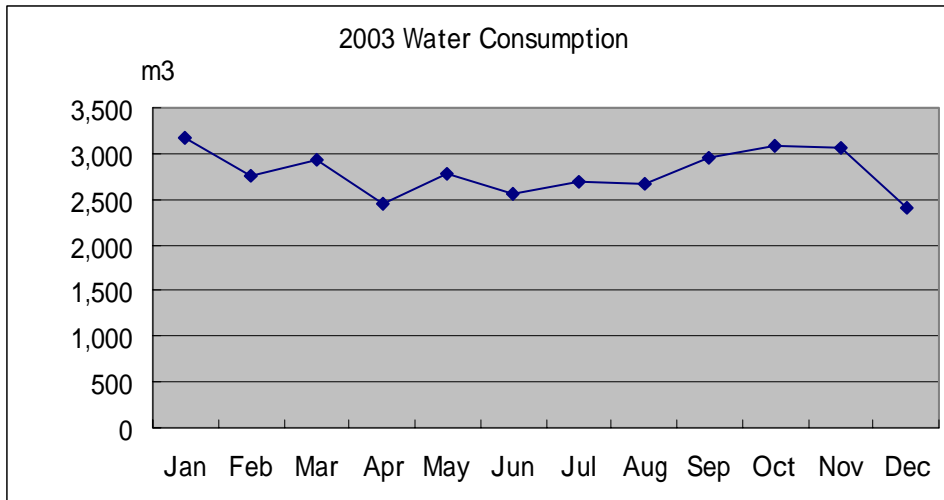

Figure V-4-10 Monthly Water Consumption

(3) Evaluation of energy consumption

1) Evaluation of electric energy consumption

Since there was no data in the Philippines regarding the annual electric energy consumption per unit floor area (Energy Efficiency Index (EEI)) which is used as the guideline for efficient use of energy, we compare the electric energy consumption in DPC Place with the data of the office buildings in Japan (222 kWh/m²y).

As the following table shows, the EEI of DPC Place is 120 kWh/m²y (163 kWh/m²y when the parking space is excluded), which is lower than that of the office buildings in Japan.

Table V-4-1 Annual Electric Energy Consumption per Unit Floor Area

GFA	24,836 m ²
GFA(ex Parking)	18,309 m ²
2003 Electricity	2,990,750 kWh
EEI (Total)	120 kWh/m ²
EEI(Ex. Parking)	163 kWh/m ²
Japan's Office	2,180 MJ/m ²
MJ kWh : 1/9.8	
Japan's Office	222 kWh/m ²
/	54%
/	73%

Figure V-4-11 Annual Electric Energy Consumption per Unit Floor Area in DPC Place and a Japanese Building

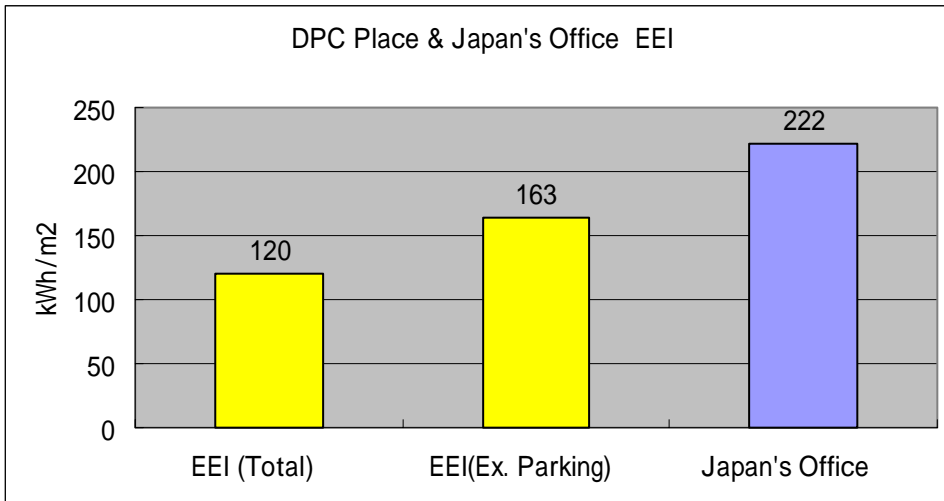

2) Evaluation of water consumption

The water consumption of DPC Place in 2003 was 24,836 m³, which is 1.35 m³/m² per unit floor area. This value is higher than the average (1.0 m³/m²) of the office buildings in Japan.

Figure V-4-12 Annual Water Consumption per Unit Floor Area in DPC Place and a Japanese Building

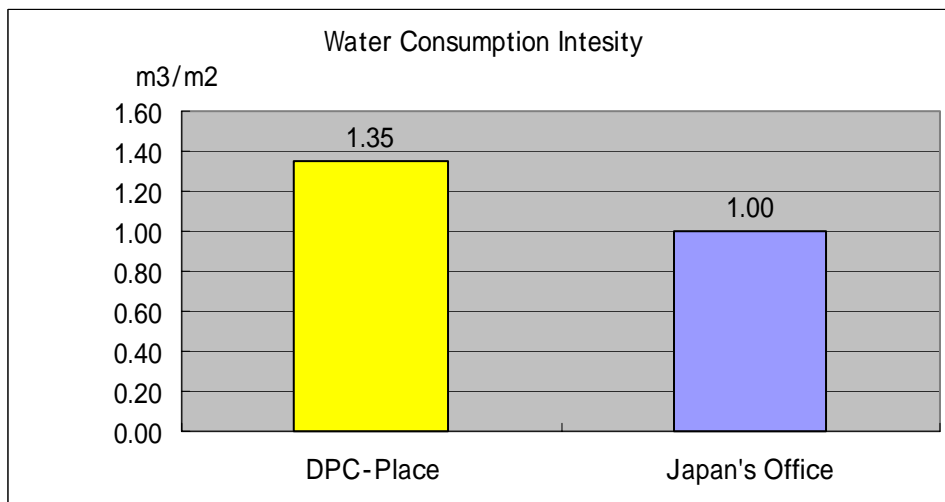

3) Considerations

The exterior and interior of DPC Place were very sophisticated and you could not tell whether it was renovated or not unless you were told. We were impressed with the high quality management of the building.

Although the building was located near the road with much traffic, we did not hear any external noise inside. On the other hand, the substation was old, and

the control board and the transformers were large and seemed old. They might have been installed at the first opening.

The efficiency of these devices is probably worse than the new ones.

The controllers of the elevators were equipped with digital variable-speed drives for comfort and energy conservation.

Water cooled packaged air conditioners (10 to 20 HP depending on the load) on each floor were used for air conditioning. They were very simple.

The electric energy consumption intensity was lower than Japan, which shows good energy conservation. The water consumption was greater than the office buildings in Japan, which may indicate leakage.

4.3 Points for Improvement and Expected Effects

Since the building was extensively renovated, we found some inadequate designing. For example, the capacity of the transformer (300 kVA) was excessive for the actual required electric power (1,000 kW) and the rated voltage of elevators was 400 V while the supply voltage was 220 V, which required increasing the voltage by adding a transformer.

Other problems include: the room temperature setting was too low, the electric energy needed to be managed for each feeder, more high-efficiency lightings should be used in tenant area, and the lightings in the machine room and the electricity room should be turned off when they are not used. We suggested improvement on these issues.

(1) Optimization of the room temperature setting

The temperature setting of the air conditioners in DPC Place was very low and we felt cold in 30 minutes after we got in the building even though we wore jackets. When we measured the temperature, it was 23.2°C.



Figure V-4-13 Measurement of the Temperature

In Southeast Asia countries, strong air conditioning is usually favored and low temperature settings are common in tenant buildings.

By increasing the temperature setting in DPC Place from current 23°C to 25°C, the power for air conditioning can be reduced. The reduction of electric energy consumption will be 100,002 kWh a year, which is 3.3% of the total electric energy.

Table V-4-2 Effects of Reduced Electric Energy by Changing the Temperature Setting

Current Temperature	23
Recommend Temperature	25
Effect	20 %
Compressor Electricity (Assumption)	500,008 kWh
Reduction	100,002 kWh
DPC Annual Consumption	2,990,750 kWh
Reduction % per annual	3.3%

(2) Turning off the lights when unnecessary

When we entered the electricity room and the generator room, the rooms were lit. Usually there were no people in these rooms and energy can be conserved by turning off the lights since the rooms do not require lighting.



Figure V-4-14 Lights in the Machine Room and the Generator Room

(3) Use of highly efficient lightings

The current indoor lights (36 W x 2 lamps) should be replaced with two 32-W highly efficient fluorescent lamps.

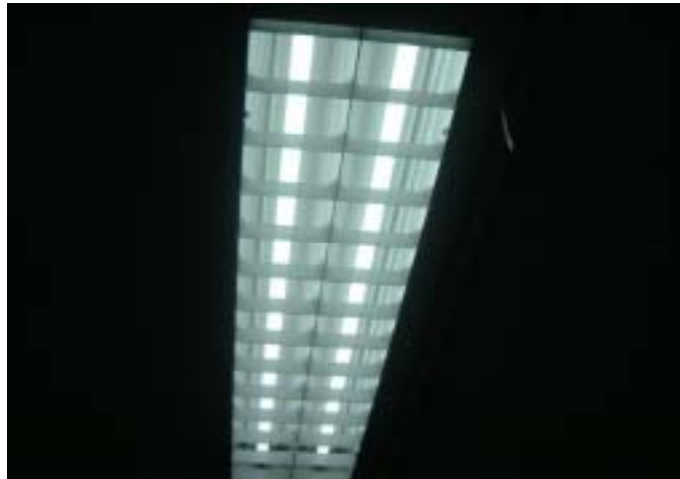

Figure V-4-15 Highly Efficient Lightings

(4) Measurement of the electric energy consumption for each feeder

DPC Place was conducting an energy conservation operation by manually starting and stopping the equipment every day. However, for further energy conservation, the electricity consumption needs to be recorded and analyzed by load and by time. They should add a watt-hour meter on each feeder or measure the electric energy consumption hourly by using a handheld watt-hour meter to check if electric energy is used inefficiently or the feeders are run inefficiently. By doing so, they can find other points to be improved to reduce energy by another few percent.

(5) Stopping the elevators at night

The elevators operated 24 hours. Since there seems to be no user at night, the elevators should be stopped to reduce energy.

(6) Replacement of the old transformer

The loss of the transformer can be reduced by replacing the existing 3,000-KVA transformer with a new 2,000-KVA transformer.

Assumed loss (current): $3,000 \text{ KVA} \times 1.5\% = 45 \text{ kW/h}$

Assumed loss (after replacement): $2,000 \text{ kVA} \times 1.0\% = 20 \text{ KW/h}$

Reduced loss (one year): $(45 \text{ KW} - 20 \text{ KW}) \times 24 \text{ h/d} \times 365 \text{ d/y} = 219,000 \text{ KWh/y}$

Table V-4-3 Electric Energy to be Reduced by Replacing the Transformer

Reduction	219,000 KWh
DPC Annual Consumption	2,990,750 KWh
Reduction % per annual	7.3%



Figure V-4-16 Old Excessive Transformer

(7) Direct power supply for elevators

Although the rated voltage of the elevators was 400 V, the distribution voltage was 220 V and it was increased by using a transformer. By choosing a transformer that can produce 400 V when the old transformer is replaced as mentioned in (6), there is no need to install a voltage-raising transformer, and the transformer loss can be eliminated.

5. About the Result of the Workshop

5.1 Outline

Eighty-eight people participated in the workshop, which was the largest number in the building workshops held this year. The Philippines gave three presentations on energy conservation improvement examples in buildings and excellent examples, and other ASEAN countries gave four presentations.

Mr. Abaya, Undersecretary of the Ministry of Energy (DOE), was scheduled to participate in the workshop. However, he could not attend and Ms. Borra, Director, came in place for him. The participants came from a variety of fields, including government officials, people from universities and building-related associations, civilians working in the field of buildings, and ESCO people. The Filipinos had the chance to exchange information and views among themselves, which is an indication of a successful workshop since its purpose is to share and disseminate information.

Since English is commonly used in the Philippines, questions and discussions were efficiently and intensively conducted.

Through the discussions, we clearly noticed the participants' high awareness of the importance of energy conservation and their strong will to promote energy conservation. We also understood the reason behind this: the energy price was determined by the market mechanism and it was high like in Singapore. They were uncertain about the energy security in the future. When an adequate policy is established, we believed the energy conservation will progress further in this country.

5.2 Discussion on the Survey Results (Obstacles in Performing and Disseminating Energy Conservation Measures and Countermeasures)

We reported the results of the follow-up survey in Tower One & Exchange Plaza (office building) and the results of the energy audit in DPC Place (office building). In each case, the top management and administrators, who listened to our reports, gave comments on our suggested improvement plans, and showed their directions for future activities. Since Mr. Domingo, Focal Point of DOE, participated in both presentations, DOE will follow-up the future activities.

The details are not described here since they are described elsewhere in this report.

5.3 Policy on Creating the Technical Directory

We explained the basic idea and suggested some elements of the Technical Directory at the workshop and obtained approval from the participants. The features are as follows:

- TD should include the technologies that are suitable for Southeast Asia and those that have been recommended by Japanese experts or those actually used in Japan.
- TD should include successful examples of the above.

- ASEAN should prepare the basic format that can be easily expanded or changed in the future based on the above.

We talked with DOE and the related people on another occasion and requested again the creation of the Technical Directory in the future.

Workshop Program in the Philippines

08:00 – 08:30	Registration
08:35 – 08:40	Opening Statement Dr. Weerawat Chantanakome Executive Director, ASEAN Centre for Energy
08:40 – 08:45	Opening Statement Mr. Yoshida Kazuhiko, General Manager, ECCJ
08:45 – 08:50	Keynote Address and Welcome Remarks Mr. Peter Anthony A. Abaya Undersecretary, Department of Energy (Ms. Teresita M. Borra (Director, DOE))
08.50 – 09.00	Coffee Break & Photo session
<hr/>	
Session I :	Policies and Programs on Energy Conservation
09.00 – 09.20	Energy Conservation Policy and Programs of the Philippines Mr. Marlon M. Domingo (Energy Utilization, DOE)
09.20 – 09.40	Japan’s Energy Conservation Programs Mr. Kazuhiko Yoshida (General Manager, ECCJ)
09.40 – 10.00	Question and Answer
<hr/>	
Session II :	Energy Conservation Best Practices for Buildings in the Philippines
10.00 – 10.30	Experience and Application of Tower One and Exchange Building
10.30 – 11.00	Experience and Application of Energy Conservation in RCBC Plaza Tower Building
11.00 – 11.30	Experience and Application of Energy Conservation in The 6750 Office Tower Building
11.30 – 12.00	Question and Answer
12.00 – 13.00	Lunch Break
<hr/>	
Session III :	Energy Conservation Best Practices for Buildings in ASEAN Countries
13.00 – 13.30	Revenue House Building of Singapore Mrs. Tan-Yeo Wei Kuen, IRAS Building, Singapore
13.30 – 14.00	EGCO Building of Thailand Mr. K. Suksit, EGCO, Thailand
14.00 – 14.30	Royal Plaza on Scotts of Singapore Edward Kway, Director of Engineering
14.30 – 15.00	Securities Commission of Malaysia Mr. T. L. Chen, Malaysia
15.30 – 16.00	Question and Answer
16.00 – 16.15	Coffee Break

Session IV :	The Way Forward
16.15 – 16.35	Development of Technical Directory by ECCJ Mr. Kazuhiko Yoshida
16.35 – 16.50	Development of Local Database / Benchmark / Guideline by ECCJ Mr. Kazuhiko Yoshida
16.50 – 17.00	Closing Statement Ms. Teresita M. Borra Director, Energy Utilization Management Bureau

5.4 Discussion for Establishing the Database, Benchmarks, and Guidelines in the Philippines

In the workshop, we explained the basic idea including how the system should work. The activities must be in cooperation with the ASEAN Benchmarking being performed by Singapore and other ASEAN countries. However, the establishment of the database, benchmarks, and guidelines for the Philippines must be planned first.

According to the people of the Ministry of Energy, they had some energy audit data regarding the buildings which were audited by the energy audit team of DOE. However, they said they had to modify the data to establish a fully-operational database.

Philippine Energy Conservation Center, Inc. (PECCI) and ESCOs also perform energy audits. If DOE can collect data from these organizations, a more comprehensive database can be created. There are also ways to collect data by contracting with researchers as suggested by ACE, which needs to be discussed in the future.

We requested the Philippines to start establishing the database, benchmarks, and guidelines according to the above suggestions.

VI. Approach as ASEAN

1. Summary Workshop Overview

On February 7, 2005, a summary workshop was held in Singapore, attended by the representatives of the ASEAN countries (Focal Point). The workshop intends to share the achievements of activities in the four countries, and to discuss the creation of the technical directory and establishment of databases, benchmarks and guidelines to make a future basic program. Following the summary workshop, a post-workshop was held. Table VI-1 describes the summary program.

The following lists the participants from the ASEAN countries.

Mr. Abdul Rashid B Ibrahim, Deputy Executive Director, Energy Market Authority, Singapore

Dr. Weerawat Chantanakome, Executive Director, ACE

Dr. Prasert SinsukPrasert, BERC, DEDE, Thailand (Chairman)

Mr. Zulkarnain B H Umar, Engineer, Energy Market Authority, Singapore

Mr. Asfaazam Kasbani, PTM, Malaysia

Ms. Azah Ahmad, Research Officer, PTM, Malaysia

Mr. Marlon Romulo U. Domingo, Science Research Specialist, DOE, Philippine

Mr. Lien Vuthy, Head of Energy Efficiency and Standard Office, MINE, Cambodia

Mr. Khamso, Chief of Electricity Management Div., Ministry of Industry & Handicraft, Laos

Ms. Marayam Ayuni, Deputy Director, Ministry of Energy and Mineral Resources, Indonesia

Mr. Aung Kyi, Director, Myanmar Industrial Construction Services

Mr. Christopher Zamora, Manager, ACE

Dr. Lee Siew Eang, Professor, National University of Singapore, Singapore

Mr. Majid Haji Sapar, Research Fellow, National University of Singapore, Singapore

Participants from the Energy Conservation Center, Japan

Executive director: Tsuzuru Nuibe

General managers of the International Engineering Department: Kazuhiko Yoshida and Yoshitaka Ushio

Technical experts of the International Engineering Department: Hideyuki Tanaka, Fumio Ogawa, Akira Kobayashi and Takashi Sato

The summary workshop dealt with reported results of discussions on the surveys and the workshops in the four countries. The representatives of the ASEAN countries presented their own technical directories, and reported on the situation of the establishment of databases, benchmarks and guidelines in their countries. Following this, we discussed the future creation of the technical directories, and establishment of databases, benchmarks and

guidelines for the countries.

In addition, the relevant members reported on “ASEAN Benchmarking for building” in the ASEAN countries, particularly in Singapore. Then, they addressed activities of “Board of Judges (BOJ)”, the commission which is assessing the award system of EE&C (Energy Efficiency and Conservation) of best practice for buildings. We have shared information, and discussed of these contents.

Some relevant members proposed their idea, including their requests, of the ASEAN Energy Management System and we explained basic concepts of this System. Based on these reports and explanatory contents, we discussed the future policy for solving problems.

Finally, we dealt with the future policy, finally reaching the mutual agreement.

2. Results of Addressing Barriers and Measures for the Promotion of Energy Conservation on Buildings

As described above, the results of the follow-up surveys and the energy audits were reported to the managers of all the relevant buildings under the presence of the respective Focal Point.

The following sets out only the important points with details omitted.

(1) Results of the follow-up Survey

Generally speaking, improvement measures for energy efficiency in the buildings, which we proposed through the past energy audits, have been well implemented. In addition, there were some examples that they took for their own specific improvement measures. In this background, there were facts that excellent engineers have been involved in building management and maintenance, as well as that their higher-rank staff members and managers well understand the importance and effects of energy conservation. We hope that those personnels will attend workshops and present their achievements as ASEAN’s models in future.

(2) Results of the energy audit

The results of energy audits were almost the same as the ones of follow-up surveys. Many buildings have already implemented energy conservation activities and we have found many model cases of ASEAN best practices for buildings.

(3) Barriers against and measures for the promotion of energy conservation

Through the above survey, we knew that the promotion of the energy conservation is very difficult without the excellent engineers’ abilities and the managers and owners’ better understanding and awareness on the energy conservation. Good

examples should be referred for the countermeasures for improvement.

In such companies, there is also one common barrier which is lack of tenants' awareness of energy conservation. From view point of customer's satisfaction, the situation makes it difficult to set a higher cooling temperature. Finally, this problem will be solved only through enlightenment of energy conservation to all the people in ASEAN countries.

Furthermore, the owners are most interested in profit maximization. They, of course, do not invest for the improvement work with low investment efficiency. In the ASEAN countries except Singapore and the Philippines, low energy price policy supported by government subsidies causes this problem. In those countries, owners will not actually invest on expensive improvement work without significant cost saving by the energy conservation. For energy conservation improvement work, it is necessary to get big improvement of energy efficiency with inexpensive equipment. However, there is a possibility of realization of the improvement plan. Under such circumstances, Japanese experts have proposed the measures for high improvement effects with small cost. We think that it is important to undertake those measures. Through activities, relevant parties can enhance their capability, and the owners can understand the importance and effects of energy conservation. In this aspect, the audited buildings give us many good examples.

Careful correct understanding of future energy trends would tells that the energy price will be raised to make it difficult to secure energy resources. In particular, with this viewpoint the manager and the owner should make preceding investment in consideration of the future useful improvement. The governments should rapidly build-up the infrastructure that can support the investment in energy conservation in terms of funds and technologies.

The workshops actually requested governmental support in ASEAN countries. They also requested further Japanese supports, in particular, the Energy Conservation Center to provide further technological support.

After the surveys or audits, some building managers asked for technological advice for further energy conservation and business improvement. We responded to their request with some proposals.

3. Creation of the Technical Directory, and Discussions of Dissemination Policies

Following the workshops, we revised the basic form of the technical directories (TD) for actual preparation, sent to the ASEAN countries to ask them for preparation. The TDs created this year were presented in the summary workshop. They are filed in chapter VII.

In this year, we made the first attempt to create the technical directory same as in the major industrial sectors. On the other hand, we have found that some of the ASEAN countries have similar technical directories. We can, therefore, utilize some of those technical directories. One of the purposes of this project is to compile technical directories which the user can easily understand and utilize. We have accepted the following configuration. In

other words, we will introduce not only advanced technologies but also successful cases and case studies in the ASEAN countries.

(Part 1) Summary table

Item	Name of Technology	Outline (Principle / Feature / Application)	Typical EC Effects (Saved Energy)	Typical Economy (Saved Cost)
1				
2				
3				
.				

(Part 2) Technological explanations

Item No. 1	Name of Technology	
Outline / Features	(Description)	
Principle / Mechanism	(Description)	
Features		
Specifics	(Description)	
Typical Effects	(1) Saved Energy	
	(2) Saved Cost / Investment	
	(2) Saved Cost / Investment	
	(2) Saved Cost / Investment	

(Part 3) Successful case studies in the ASEAN countries

Item No. 3	Name of Technology
Case No. 3 - 1	Name of Project
Item No. 2	Name of Technology
Case No. 2 - 1	Name of Project
Item No. 1	Name of Technology
Case No. 1 - 1	Name of Project
Specifics of Project	(Description)
Results of Activities	(Description)
Actual Effects	(1) Saved Energy
	(2) Saved Cost / Investment

Some countries made questions and comments on who is responsible for such time consuming work but we think that each Focal Point should cooperate with the relevant buildings to start from the following tasks.

- To introduce technologies which were recommended and implemented in the buildings during the energy audits in the past
- To introduce technologies applied to buildings which won the award of EE&C best practices for buildings.
- To introduce developed technologies to be applied to the ASEAN countries for themselves
- To collect case studies on technologies applicable to existing technical directories in ASEAN countries

In consideration of the workload of the Focal Points, we have to take into account the human resources which can be shared by the ASEAN countries when this approach works successfully and the job amount increases.

4. Discussions on the Establishment of Databases, Benchmarks and Guidelines

This project aims to establish databases, benchmarks and guidelines for buildings in the ASEAN countries in consideration of significant differences in weather conditions, business environment and living habits among the countries.

This project also intends to link with the activity of “ASEAN Benchmarking” in the ASEAN countries. It is targeted to establish and implement ASEAN’s own system so that the system of each ASEAN country will be interconnected in future. “ASEAN Benchmarking” focuses on standardization of the approach of the data processing and the benchmark evaluations, and on the application in the ASEAN countries.

The purpose of this project is to collect and manage original data provided by countries in response to “ASEAN Benchmarking” and at same time to implement a system of establishment and application of the benchmarks and the guidelines applicable to the ASEAN countries for energy conservation for buildings. As the result of this activity, collected reliable data will be able to be shared by the ASEAN countries. In the summary workshop, Dr. Lee of the Singapore University as a leader of the project presented recent activities of the project in order to share “ASEAN Benchmarking” achievements and information. The summary of the activities of this project is described below:

Lately, item (1) has been completed and (2) followed

(1) Whole Building Benchmarking

This is the idea of the criteria for the evaluation of the energy intensity for each category of buildings such as hotels, business offices, hospitals, etc.

(2) System Benchmarking

This is the idea of the criteria on the evaluation of the energy intensity for each equipment unit such as air conditioners, chillers, AHU units, and other building equipment and facilities

In the present stage, this project activity includes build-up of the databases for the above items (1) and (2) (including building design factors) to establish the system of databases, benchmarks and guidelines applicable to the ASEAN countries. At the same time, setting of benchmarking includes item (3) which incorporate the effect factors, and adds the tools of statistical analyses as well as comparison analysis and factor analyses. In addition, the basic concept covers item (4) which incorporate the factors which should be solved for making a guideline.

(3) Weather conditions (temperature, humidity and other data), working conditions (including working hours), and cultural and religious conditions

(4) Obstacles and problems in the achievement of benchmark

This basic concept has been introduced in the workshops, and acquired fundamental agreement. The actual implementation will depend on the future activities.

In the future, this project should unify the activities in these countries, establish the system of databases, benchmarks and guidelines and develop the information box which the representatives of these countries can use for their purposes. For this purpose, IT experts will be employed in the ASEAN countries.

Figure VI-1 illustrates the system for databases, benchmarks and guidelines, and its implementation concepts.

Figure VI-1 System for Databases, Benchmarks and Guidelines, and Its Operation Concepts

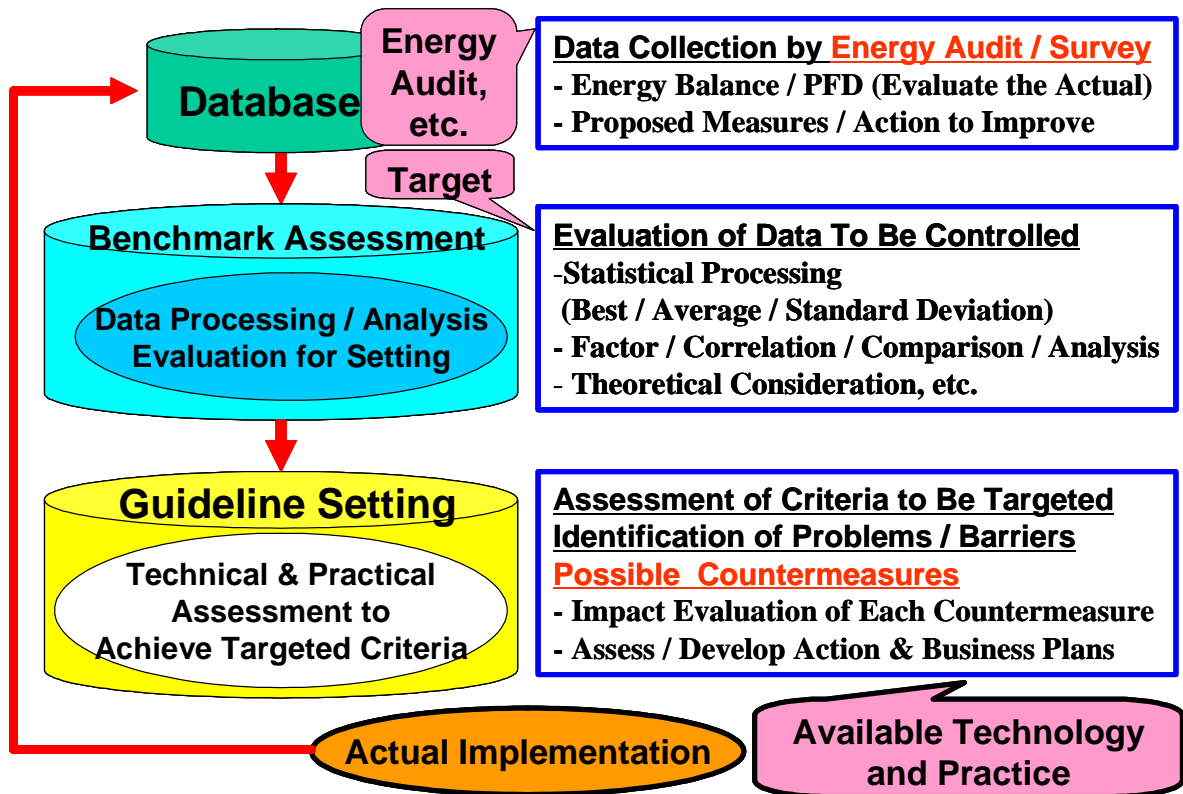

08:00	-	08:30	REGISTRATION
08:30	-	08:55	Opening Session - Statement from the Host Country - Opening Keynote Speech by Mr. Tsuzuru Nuibe (ECCJ) (Preliminary Title) Vision of Future Development for PROMEEC Project in ASEAN - Opening Statement from Dr. Weerawat Chantanakome (ACE) - Opening Statement from EE&C-SSN
08:55	-	09:00	Adoption of the Agenda and Election of Rapporteur
SESSION 1			PROMEEC - MAJOR INDUSTRY
09:00	-	12:30	
12:30	-	13:30	Lunch
SESSION 2			PROMEEC – BUILDING
13:30	-	14:15	Summary of Local Workshops by ECCJ Results of Follow-up Surveys at Indonesia / Cambodia / Thailand / Philippines - Status of Implementation and Dissemination - Discussion Results : Barriers and Possible Measures
14:15	-	14:30	Q & A
			Presentation : Prepared Technical Directory and Status & Plan of Database / Benchmark / Guideline Preparation
14:30	-	14:45	Presentation by Indonesia
14:45	-	15:00	Presentation by Cambodia
15:00	-	15:15	Coffee Break
15:15	-	15:30	Presentation by Thailand
15:30	-	15:45	Presentation by Philippines
15:45		16:00	Q & A
16:00	-	16:20	Edition of Technical Directory (To be led by ECCJ)
16:20	-	17:00	Presentation by Dr. Lee, or Explanation by ACE based on Dr. Lee’s Report - Actual Results of Activities for ASEAN Benchmarking for Building for 2004-2005 Report by BOJ Member : - Actual Results of Activities of BOJ for 2004-2005
17:00	-	17:15	Plan to Develop Database to Be Shared by 10 Countries (To be led by ECCJ)
17:15	-	17:30	Explanation & Discussion : Proposed Plan for 2005 – 2006 by ECCJ
			END of Sessions for Feb. 07, 2005

Table VI-1 Summary Workshop Program

VII. Created Technical Directory

Part – 1 : Summary (1. Air Conditioning)

1. Air Conditioning

(Item – 1)

1. Air Conditioning

Sheet No of all	Sheer of the Building	Improving measure		Out line	Effect of Energy Saving		Cost and Benefit	
		Item No.	Name of Improving measure		Energy Saving	Oil reduction	Cost	Recovery period
1	1	1	AC equipped with Heat Pipe	Air Conditioning Unit Equipped with Heat Pipe for Tropical Climate (AC without Heater)	15~20%.	15~20%.	0	0

(Item – 2)

A. Common

1. Air Conditioning

Sheet No of all	Sheer of the Building	Improving measure		Out line	Effect of Energy Saving		Cost and Benefit	
		Item No.	Name of Improving measure		Energy Saving	Oil reduction	Cost	Recovery period
1	1	1	Energy Saving Module (Abbotly) for Compressor Control	The micro-computer based control which minimises consumption and regulating operation of compressor	10 -30%	-	-	1 - 2 Year

(Item – 3)

1. Air Conditioning

Sheet No of all	Sheer of the Building	Improving measure		Out line	Effect of Energy Saving		Cost and Benefit	
		Item No.	Name of Improving measure		Energy Saving	Oil reduction	Cost	Recovery period
			VSD on A/C Pumps(Chilled Water and Condenser Water)	Variable Speed Drive on Pump Motor to Control Pump Output Resulting to Reduced Power Consumption.	25%		US\$200/kW	2 1/2 years

Part – 1 : Summary (2. Electricity)

(Item – 1)

2. Electricity								
Sheet No of all	Sheer of the Building	Inproving measure		Out line	Effect of Energy Saving		Cost and Benefit	
		Item No.	Name of Improving measure		Energy Saving	Oil reduction	Cost	Recovery period
1	1	1	LightSave (LSA2000B) Lighting Load Reduction	The engery saving device operates by reducing the lighting load there by reducing power consumed	30%	-	-	1 - 3 Year

(Item – 2)



2. Electricity

Sheet No of all	Sheer of the Building	Inproving measure		Out line	Effect of Energy Saving		Cost and Benefit	
		Item No.	Name of Improving measure		Energy Saving	Oil reduction	Cost	Recovery period
1	1	1	AVR and Load Management	Automatic Voltage Regulator and Load Management System	7-15% KW			

(Item – 3)

2. Electricity								
Sheet No of all	Sheer of the Building	Inproving measure		Out line	Effect of Energy Saving		Cost and Benefit	
		Item No.	Name of Improving measure		Energy Saving	Oil reduction	Cost	Recovery period
1	Office	1	Building Automation System (BAS)	BAS is a computer-based monitoring to coordinate, organize and optimize building control sub-systems such as the heating, ventilating and air conditioning (HVAC) equipment and alarm systems	9% - 12%	-		

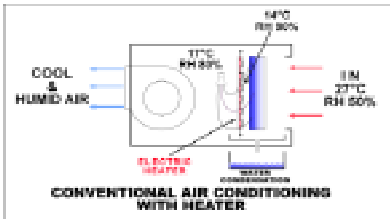
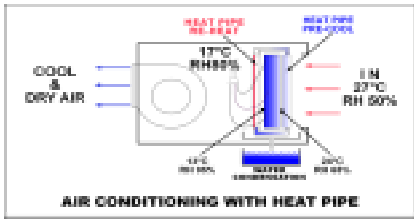
Part – 2 : Technical Description (Air Conditioning : Item – 1)

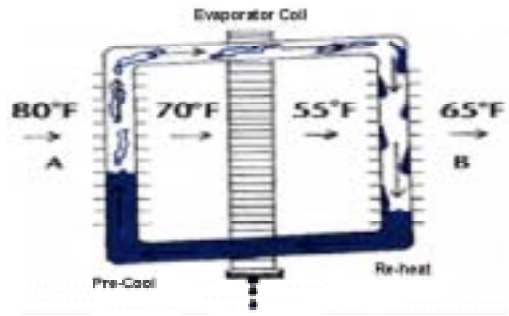
[Type of Building] All			Energy Source Electricity		
[Category of Technology] Air Conditioning	Name	AC equipped with Heat Pipe	Year of Practical use 1999		
[Outline]	<p>Air Conditioning unit equipped with heat pipe specially designed for Tropical Climate (Tougher than Sub Tropic)</p> <p>The Climate Difference</p> <ul style="list-style-type: none"> · Sub Tropic <ul style="list-style-type: none"> - Hot and Dry - Low Wet B · Tropic <ul style="list-style-type: none"> - Hot and Humid 				
[Concept/Function/Specialty]	<table border="0" style="width: 100%;"> <tr> <td style="width: 50%; vertical-align: top;"> <p>Conventional Type (AC + Heater)</p> <ul style="list-style-type: none"> · Consume electricity for heater · Base AC Capacity </td> <td style="width: 50%; vertical-align: top;"> <p>AC equipped with Heat Pipe</p> <ul style="list-style-type: none"> · No electricity for heater · Smaller AC Capacity (can be reduced) </td> </tr> </table> <div style="display: flex; justify-content: space-around; margin-top: 10px;">   </div>			<p>Conventional Type (AC + Heater)</p> <ul style="list-style-type: none"> · Consume electricity for heater · Base AC Capacity 	<p>AC equipped with Heat Pipe</p> <ul style="list-style-type: none"> · No electricity for heater · Smaller AC Capacity (can be reduced)
<p>Conventional Type (AC + Heater)</p> <ul style="list-style-type: none"> · Consume electricity for heater · Base AC Capacity 	<p>AC equipped with Heat Pipe</p> <ul style="list-style-type: none"> · No electricity for heater · Smaller AC Capacity (can be reduced) 				
[Explanation of the Technology] · Process Flow · Structure and/or Composition · Schematic Diagram	<p>Principle of Heat Pipe In one end part coolant absorbs heat and evaporates, in the other end, coolant dissipates the heat and condenses</p> <div style="text-align: center; margin: 10px 0;">  </div> <p>The Use of Heat pipe in AC Hot and humid outer air is pre-cooled by heat pipe. Dehumidified and undercooled</p> <div style="text-align: center; margin: 10px 0;">  </div>				

Part – 2 : Technical Description (Air Conditioning : Item – 2)

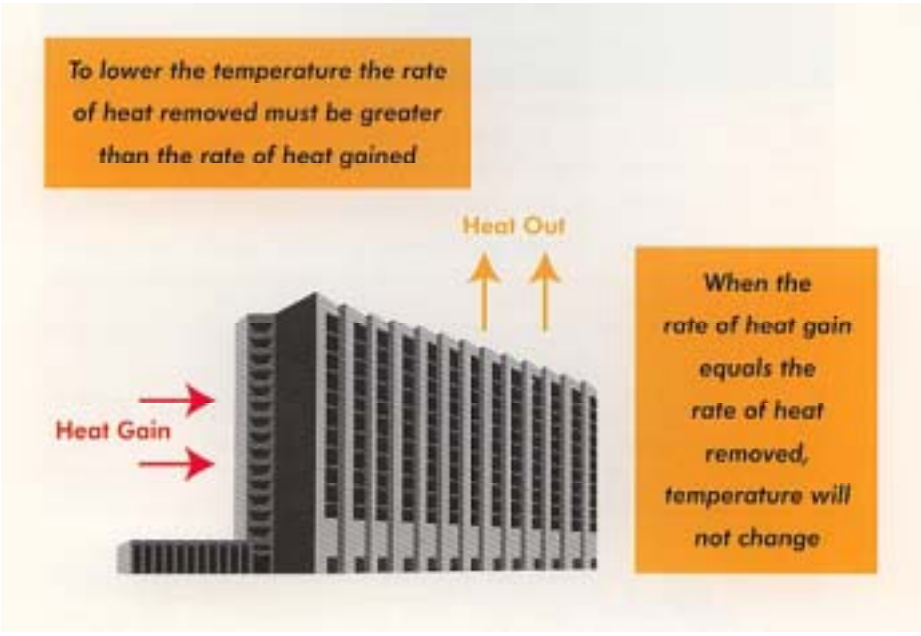
[Type of Building] All			Energy Source
[Category of Technology] Air Conditioning	Name	Energy Saving Module (Abbotly)	Electrical
[Outline]	Practical use day		
	<p>The Energy Saving Module is a micro-computer based control which minimizes power consumption by monitoring and regulating the operation of the compressors in refrigeration and air conditioning systems.</p> <p>The Energy Saving Module's optimization function increases the rate of heat removal, which reduces the running time of the compressor, achieving a</p> 		
[Concept/Function/Specialty]	<p>Conventional controls are designed to switch the compressor on at the fixed" cut in" or high limit and switch off at the "cut out" or low limit. The difference between the high and low limit is called the <i>differential or dead band</i>. This band is fixed and cannot be varied in conventional systems.</p> <p>When the compressor first starts at the cut in point, it will be operating at maximum efficiency with a high suction pressure. As the conditioned space temperature is reduced, the suction pressure reduces and compressor capacity is reduced. Each degree of temperature reduction therefore, takes a longer period of time and uses more energy.</p> <p>Micro-computer technology has enabled Abbotly Technology to develop a unique compressor optimization strategy; Proportional Differential Adjustment (PDA).</p> <p>Unlike conventional control systems, this PDA technology will automatically adjust the control differential, the "cut in" and the "cut out" points, in response to</p>		

[Concept/Function/Specialty]

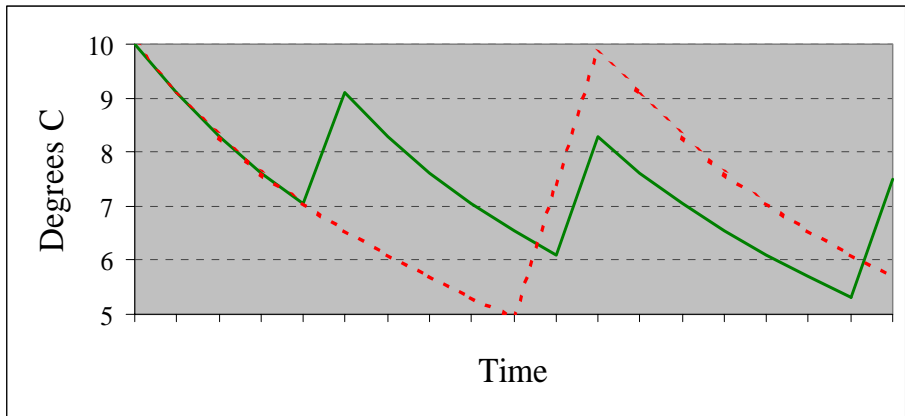

[Explanation of the Technology]

- Process Flow
- Structure and/or Composition
- Schematic Diagram

Network Controller

The Network Controller contains the Central Processor Unit that can control four System Interface Modules (SIM).

The key pad on the Network Controller enables configuration of the local network, remote network, access to data and bypass selection.

Continuous monitoring of the system status and level of savings being achieved is available on the digital display and remotely through the communication system.

System Interface Module

Each "System Interface Module (SIM)" has two electrically separate, independent channels with normally open and normally closed switching.

Installation is simple with the SIM connected in series with the air conditioning or refrigeration control circuit.

A 24 pin male connector on each side of the SIM, enables direct, side by side connection to the Network Controller and other SIMs.

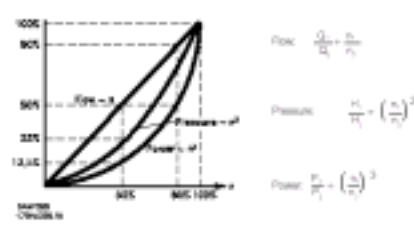
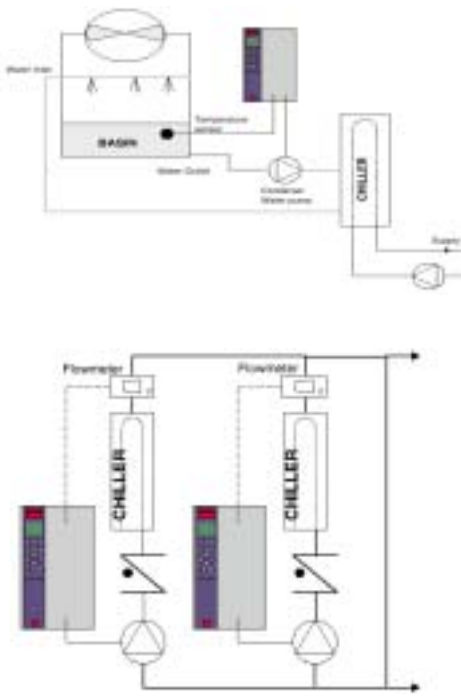

Part – 2 : Technical Description (Air Conditioning : Item – 3)

[Type of Building] Common			Energy Source Electricity
[Category of Technology] Air Conditioning	Name	Variable Speed Drive on Air-conditioning System Chilled Water Pump and Condenser Water Pump	Year of Practical Use 2002
[Outline]	<p>Air-conditioning System Chilled Water Flow and Condenser Water Flow are designed for maximum flow. Real time operation of Air-conditioning will require water flow at less than maximum value. Variable Speed Drive (VSD) Control is an efficient technique to</p>		
[Concept/Function/Specialty]	<p>The laws of proportionality</p> <p>This figure describes the dependence of flow, pressure and power consumption on the rpm figure.</p> <p>Q = Flow Q_1 = Rated flow Q_2 = Reducing flow</p> <p>H = Pressure H_1 = Rated pressure H_2 = Reducing pressure</p> <p>P = Power P_1 = Rated power P_2 = Reducing power</p> <p>n_1 = Speed regulation n_2 = Rated speed n_3 = Reducing speed</p>  <p>Flow: $\frac{Q_2}{Q_1} = \left(\frac{n_2}{n_1}\right)$</p> <p>Pressure: $\frac{H_2}{H_1} = \left(\frac{n_2}{n_1}\right)^2$</p> <p>Power: $\frac{P_2}{P_1} = \left(\frac{n_2}{n_1}\right)^3$</p> <p>Pump Flow Output can be varied by controlling the rotational speed of the pump. At reduced water flow rate the power requirement of pump motor is also reduced. VSD can vary the pump rotational speed by changing electrical frequency through its frequency converter.</p>		
[Explanation of the Technology] <ul style="list-style-type: none"> Process Flow Structure and/or Composition Schematic Diagram 	 <p>Variable Speed Drive (VSD) is a frequency converter that rectifies AC mains voltage into DC voltage, after which the DC voltage is converted into an AC current with a variable amplitude and frequency. The motor is thus supplied with variable voltage and f</p>		

Part – 2 : Technical Description (Electricity : Item – 1)

<p>[Type of Building] All</p>			<p>Energy Source</p>
<p>[Category of Technology] Air conditioning</p>	<p>Name</p>	<p>LightSave (LSA2000B)</p>	<p>Electrical</p>
			<p>Practical use day</p>
<p>[Outline]</p>	<p>LightSave is an energy saving device which operates by reducing the voltage to a lighting load thereby reducing the power consumed. It cuts energy bills <i>by up to 30% with only a 15% reduction in light output.</i></p> <div data-bbox="596 555 1321 900" data-label="Figure"> </div>		
<p>[Concept/Function/Specialty]</p>	<p>The lightSave energy controller for discharge lamp lighting operates at full power for an initial startup period of 5 minutes. This facilitates striking of the lamp and stabilization of discharge lamp light levels. Unlike other devices, LightSave is designed to be installed in the switch line of the controlled load rather than at the distribution board and is therefore unaffected by switching of adjacent loads.</p> <div data-bbox="574 1205 1385 1572" data-label="Diagram"> </div>		

[Explanation of the Technology]

· Process Flow

· Structure and/or Composition

· Schematic Diagram

INPUT :	240 VOLT AC 50Hz
OUTPUT :	Full power for 5 minutes after switch on. Then 70% of full power
MAXIMUM LOAD :	2000VA
WEIGHT :	5.5Kg
DIMENSION :	300 x 114 x 100
FIXING :	Horizontal or Vertical

Typical maximum number of twin 36W luminaries controllable by one unit is 40 luminaries.



Note : Exact quantity depends on control gear used and luminaries factor.



**Lightsave
(LSA2000B)**

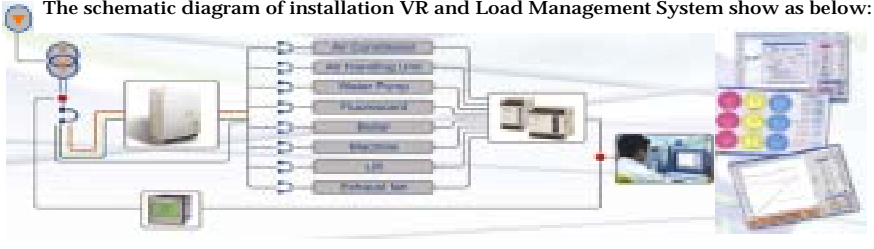

Part – 2 : Technical Description (Electricity : Item – 2)

<p>[Type of Building] Hotel and Office [Category of Technology] Regulator System</p>	<p>Name</p>	<p>AVR with Load Management System</p>	<p>Energy Source Electricity Practical use day</p>
<p>[Outline]</p>	<p>This Voltage Regulator can be functioned effectively in the Three(3) Phase-Four(4) Wires (both lamp and motor loads) which are of distribution system in Thailand. Installation just before MDB (Main Distribution Board) would be most effective and desirable because total circuits In order to increase energy saving efficiency Load Management System is complete programme assist for efficiency electric power consumption and management electric system. The program support both Thai and English language. It is able assist calculation peak demand</p>		
<p>y]</p>	<p>Main Functions of VR</p> <ol style="list-style-type: none"> 1. Regulating of Voltage in excess and balancing of Voltage and Currents. 2. Matching of Impedance and removal of Higher Harmonics. 3. Restraining of Momentary Current-up <p>Main Functions of Load Management System</p> <ol style="list-style-type: none"> 1. The Program will show the electric current for a time period in real time. 2. Able to control load in automatic, Manual and schedule modes (set the time connect-cut load). 3. Graph of Demand in the month will show the <p>The schematic diagram of installation VR and Load Management System show as below:</p> 		
<p>Technology] • Process Flow Composition • Schematic Diagram</p>	<p>Principle of AVR</p> <ol style="list-style-type: none"> 1. The AVR is a highly efficient and durable voltage regulator application to both single and three phase 3 & 4 wire types of electronicity with non-contact changeover method. 2. Maximum Voltage Control <ol style="list-style-type: none"> 1) The AVR precisely controls the out-put voltage by increments of 2% V with total of 5 taps therefore +2%, 0%, -2%, -4%, -6%. 2) The AVR can pre-set the out-put voltage by increments of 1% i.e. 100, 99, 98, 97 or 96% against the rated voltage. 3) Each phase is independently controlled. 4) The out-put voltage is displayed on the panel in real time. 3. Response Speed When the primary side voltage deviates for about 5 seconds from the pre-set value, the tap is changed over according to the fluctuation. 4. Momentary Interruption Since the method of tapping change over as opposed to the AVR is the non-contact method using thyristors, it never shuts off the power even momentarily at the time of voltage change over as opposed to the contact method. It, therefore, does not produce any 		

Part – 2 : Technical Description (Electricity : Item – 3)

[Type of Building] All	Name 	Building Automation System (BAS)	Energy Source
[Category of Technology] Electricity			Electricity
[Outline]	Building Automation Systems (BAS) optimize the start-up and performance of the heating, ventilating and air conditioning (HVAC) equipment and alarm systems. BAS greatly increases the interaction of mechanical subsystems within a building, improve occupant comfort, lower energy use and allow off-site building control		
[Concept/Function/Speciality]	BAS use computer-based monitoring to coordinate, organize and optimize building control sub-systems such as security, fire/life safety, elevators, etc. Common applications include : 1. Equipment scheduling (turning equipment off and on as required) 2. Optimum start/stop (turning heating and cooling equipment on in advance to ensure the building is at the required temperature during occupancy) 3. Operator adjustment (accessing operator set-points that tune system to changing conditions) 4. Monitoring (logging of temperature, energy use, equipment start times, operator logon, etc) 5. Alarm reporting (notifying the operator of failed equipment, out of limit temperature/pressure conditions or need for maintenance)		

[Explanation of the Technology] •Process Flow •Structure and/or Composition •Schematic Diagram	BAS include a collection of sensors that determine the condition or status of parameters to be controlled, such as temperature, relative humidity, and pressure. Similarly, output devices impart electronic signals or physical action to the control devices. Examples include electric relays or damper and valve actuators. The sensors and output devices are connected either to a unitary controller or to a distributed processor. Unitary controllers are limited to the needs of an intended function and have limited capabilities, such as memory size. Distributed processors can accommodate the needs of several unitary controllers as well as connect directly to input and output devices
--	---



Part – 3 : Successful Examples (Air Conditioning : Item – 1)

[Effect for Energy Saving]	
[Effectiveness of the improving measure]	<p>AC Equipped with Heat Pipe used in Tropic Climate</p> <ul style="list-style-type: none"> · Comfort Zone SNI can be maintained. · AC Capacity can be reduce by 15-20%. · Operation cost can be reduce by 20-30%. · Room RH can be controlled <60%, to prevent the grow of Fungi and MICROORGANISIM.
[Energy Saving]	AC Capacity can be reduce by 15~20%.
[Green House Gas Reduction(except CO2)]	Possible reduction correspondent to the reduction in electric power at power plants
[Cost and Recovery]	
[Cost]	0 (About the same as conventional AC)
[Economical Effectiveness] (Benefit and Cost)	<p>Operation cost of AC (In case of 1HP (1kW)) (Preconditions)</p> <p>Operation time : 15 hours/day, 300 days/year, Electric Power Cost : Rp.500/kWh (US\$0.055/kWh) (Operation cost)</p> <ul style="list-style-type: none"> · 1kW x 15h/d x 300d/y x Rp. 500/kWh (US\$0.055/kWh) Rp. 2,250,000.- /year (US\$24)
[Case implemented] [No.1]	<p>Not Prepared (In process of practical application)</p> <p><u>For Other Technologies, Focal Points Shall Prepare Examples.</u></p> <p><u>(As Per Presentation by ECCJ at Local Workshop)</u></p>
[No.2]	
[No.3]	
[Note]	<p><u>1. Contacts for further information</u></p> <p><u>Ir. John Budi Harjanto Listijono M.Eng.Sc</u> <u>Universitas Katolik Indonesia ATMA JAYA, Fakultas Teknik Jurusan Teknik Mesin</u> <u>PT Metroplitan Bayu Industri</u> <u>(Address)</u> <u>(TEL) _____ (FAX)</u></p>

Part – 3 : Successful Examples (Air Conditioning : Item – 2)

[Effect for Energy Saving]	
[Effectiveness of the improving measure]	The compressor operated at its optimum efficiency, compressor extended.
[Energy Saving]	10 - 30 %
[Green House Gas Reduction(except CO2)]	Possible reduction correspondent to the reduction in electric power plant.
[Cost and Recovery]	
[Cost]	Depend on compressor size.
[Economical Effectiveness] (Benefit and Cost)	

(Case implemented) [1]	Tesco Lotus 51 stores
[2]	Toshiba Semiconductor
[3]	Srithai Superwear
[Note]	

Part – 3 : Technical Description (Air Conditioning : Item – 4)

[Effect for Energy Saving]	
[Energy Saving]	1- Automatic control system: Ex: Adjusting the inside and out side temperature difference of 4oC for example and still keeping the human comfort. Ex: Out side = 30
[Green House Gas Reduction]	a/ Possible reduction correspondent to the reduction in electric power at power plants b/ Replacing AC using freon type gas by non-harmful to environment gas
[Cost and Recovery]	
[Cost]	0 (About the same as conventional AC)
[Economical Effectiveness] (Benefit and Cost)	Operation cost of AC (In case of EE of AC 0.951kW/ton) Operation time : 24 hours/day, 365 days/year, Electric Power Cost : USD0.12/KWh AC (Carrier) = 220ton Energy AC saving : 220ton x 0.95 kw /ton x 8

Part – 3 : Successful Examples (Electricity : Item – 1)

[Effect for Energy Saving]	
[Effectiveness of the improving measure]	Only 15% reduction in light output
[Energy Saving]	30%
[Green House Gas Reduction(except CO2)]	Possible reduction correspondent to the reduction in electric power at power plant
[Cost and Recovery]	
[Cost]	300 Baht/lamps
[Economical Effectiveness] (Benefit and Cost)	

[Case implemented] [1]	Tesco Lotus 51 Stores
[2]	Dusit - Arawan textile
[3]	Seven - eleven , KFC
[Note]	Total more than 3,000 Unit (120,000 Lamps)

Part – 3 : Successful Examples (Electricity : Item – 3)

[Effect for Energy Saving]		
	[Effectiveness of the improving measure]	- Reduces energy consumption from heating, ventilation, and cooling equipment - Reduces cost and time required to monitor and manage building operation
	[Energy Saving]	Rate of energy saving by BAS have variation, depend on complexity of building control sub system (HVAC equipment)
	[Green House Gas Reduction(except CO2)]	-
[Cost and Recovery]		
	[Cost]	Determining investment cost of BAS depend on the number of sub system interconnected
	[Economical Effectiveness] (Benefit and Cost)	

[Case implemented] [No.1]	Plaza BII Building (Tower 2) Energy (electricity) supply : State Electricity with installed capacity of 6.000 kVA and standby diesel generators 4 x 1.735 kVA Energy saving : 335.000 kWh/ year
[No.2]	Gran Melia Hotel Energy saving : 494.770 kWh/ year
[Note]	1. Contact for further information : Mr. A. Dewanto Purwoutomo (General Manager Plaza BII Building) Jl. MH Thamrin No. 51 Jakarta Indonesia - 10350 Owner : Sinar Mas Real Estate Division Quality Management System Certification : ISO 9002 UKAS Quality Management. Certificate No. ID03/0073 2. Contact for further information Grand Melia Hotel Jl. Rasuna Said Blok B2 Jakarta Indonesia Email : granmeliajakarta.com, www.solmelia.com

. Reference

Reference 1 : Results of the Follow-up Survey and
Energy Audit

Reference 2 : Data for the Workshop

Presentation of Achievements by ASEAN countries
(ASEAN)

Basic Concepts & Contents of the Technical Directory
(Japan)

Planned System of establishing Databases,

Benchmarks & Guidelines (Japan)

Reference 3 : Summarized Workshop Data

Report of Activities in Countries (Japan)

ASEAN Benchmarking Activities (ASEAN)

Basic Draft Plan for 2005 & 2006 (Japan)